

## Shooting multiple x-ray images efficiently

This chapter works towards a technical concept for shooting multiple x-ray images efficiently. The plan is to improve the ability of the baggage inspector to detect suspicious items in the baggage, by giving him a spatial impression of the baggage and by enabling him to look around occluding objects. To do this, the Delft Virtual Window System (see Chapter 1) will be used. The DVWS works by updating the x-ray image on the display to match the viewing position of the observer. With current technologies it is hardly possible to acquire the appropriate x-ray image in real time at the moment the observer moves. Therefore a number of available views have to be recorded prior to the presentation via a virtual window display. How can we take useful multiple images of a suitcase efficiently, and what do potential manufacturers and users expect from such a scanner?

To answer the question about how to shoot x-ray images, we need to understand the recording techniques for shooting x-ray images. Next to x-ray sources and x-ray sensors, x-ray mirrors may be useful for shooting multiple x-ray images. The first section discusses these components.

It can be expected that the manufacturer wants to integrate his own know-how in the concept that I will suggest. In order to make this feasible, the state of the art in baggage scanners and their working principle has to be understood. To find out what potential users and manufacturers will expect from an x-ray scanner, and to find out how efficient the implementation of the concept really has to be, the state of the art in baggage x-ray inspection will be discussed in section two.

The most difficult question is to determine how many and which images the inspector needs. All experiments described in this thesis deal with this question. Reasonable answers can be given about what views are useful, and about what the image quality should be. However, no conclusive answer can be given about the required perspective properties of the images. This question becomes urgent here, as x-ray images have a very unusual perspective. Therefore, the third section mainly sketches the possible perspective combinations, in order to make a reasonable choice for the perspective.

Given these answers, a number of concepts are proposed in the last section. Two concepts are worked out in more detail, optimising scanning speed, price, and operational safety.

### **X-Ray components**

The components used for x-ray image generation have to be understood to find an optimal solution for shooting a series of x-ray images. Generation and detection of x-rays and x-ray mirrors are discussed.

#### **Generating and sensing x-rays**

An x-ray source consists of a cathode and an anode with a high voltage (140 kV is typical for baggage inspection) between them (Figure 3.1). The cathode is heated so that

electrons leave the cathode. They are accelerated by the high voltage between the cathode and the anode, and crash into the anode. In the anode, 99% percent of the energy the electrons have at the time of impact is converted into heat. Therefore the anode has to be cooled, usually with oil. About 1% of the energy is turned into photons. Given the energy of the electrons of 140kV, the shortest wavelength of these photons is about 9 pm (see Schweers and Vianen, 1982).

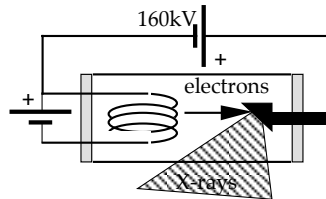

Figure 3.1. Diagram of an X-ray source. Electrons are emitted from the cathode and crash into the anode. This causes photons with high energy, i.e. x-rays, to be emitted from the anode.

The x-rays spread in all directions. In order to get a narrow x-ray beam, the source is shielded with lead, and a slit in the lead gives the x-ray beam the desired fan-like shape. The lead and the cooling make an x-ray source expensive and heavy. Typically, an x-ray source costs about NLG 20,000 (USD 10,000).

The x-rays are sent through the baggage. The higher the density of the baggage contents, and the more material it contains, the more x-rays it will absorb and scatter. Furthermore, x-rays with a higher energy are able to penetrate denser material than x-rays with lower energy. The scattering behaviour is characteristic to the material, and can thus be used to identify the materials in the baggage (Hughes, 1989).

The x-rays that remain after their journey through the material have to be made visible. X-rays can be converted to visible light if they hit zinc sulphide: the zinc sulphide will emit a green light when hit. Alternatively, scintillation crystals are used to convert the x-rays to light. These scintillation crystals have a higher efficiency than zinc sulphide. The visible light can be converted to a voltage difference with a photo diode. To optimise the signal-to-noise ratio of such a two-step detector that converts the amount of x-rays to a voltage difference, the scintillation crystal and the photo diode are usually integrated in one electronic part: an *x-ray sensor*. Typically one x-ray sensor costs about NLG 10 (USD 5). Usually a row of such x-ray sensors is used (a *sensor line*), to scan one x-ray line at once. Thus a typical sensor line with 576 sensors will cost about NLG 6,000 (USD 3,000).

### X-ray mirrors

Reflecting x-rays may be a way to multiply the number of virtual x-ray sources and/or sensors without requiring additional real sources and sensors. Such x-ray mirrors consist of a large number (typically 150) of layers of two alternating materials, one with a high and one with a low density. The distance between two of these layers is typically 0.1 - 20 nm (Figure 3.2), and should match the wavelength of the x-rays to be reflected.

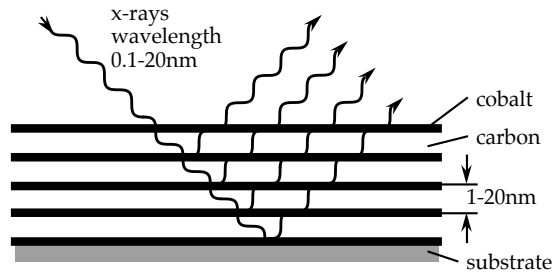

Figure 3.2. An x-ray mirror consists of a large number of layers, each reflecting a small fraction of incoming x-rays. The distance between the layers is related to the wavelength and the angle of incidence of the x-rays. Because of the multiple layers the reflected x-rays will be blurred slightly.

Each layer reflects only a small percentage of x-rays, but combined together these mirrors have an efficiency of about 10%. This may be sufficient for use in x-ray scanners, as the loss arising in the mirrors can be compensated by generating a higher x-ray dose. This higher dose should not be sent through the baggage, thus the x-rays should be reflected before they are sent through the baggage.

X-ray mirrors have a number of properties that may be critical when they are used in a baggage scanner. First, the amount of reflection is not constant for different angles of incidence. Second, such mirrors are still expensive, as the layers have to be extremely highly polished. Accurate prices for x-ray mirrors are not known, because they have to be custom-made. Third, I have no knowledge of whether x-ray mirrors exist which are capable of reflecting the high energy x-rays used with baggage inspection (typically, 0.01 nm).

In conclusion, x-ray mirrors may be an interesting way to multiply the number of x-ray sources and sensors, which is a requirement for multiple-view x-ray baggage inspection. However, it is not clear whether x-ray mirrors with properties suited for our purpose exist. The next section discusses the various ways of building a scanner given the components, and sketches the state of the art in x-ray scanning.

## X-ray scanners- state of the art

In order to know what potential users and manufacturers will expect from an x-ray scanner, and to understand how efficient the concept has to be, this section discusses the state of the art in x-ray baggage inspection. Important points are scanning speed, image resolution, image processing, the amount of x-rays to which the baggage is exposed and the availability of multiple views.

Instead of discussing these points separately, I will group the machines into three types of sensor mechanism: (1) those using a fluorescent screen, (2) those using a sensor line and (3) Computer Tomography (CT) scanners (Figure 3.3).

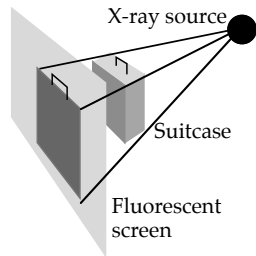

Figure 3.3a. A Fluorescent screen can convert the x-rays directly into a visible image. Because the x-rays are partly absorbed by the baggage, the image is the shadow of the suitcase.

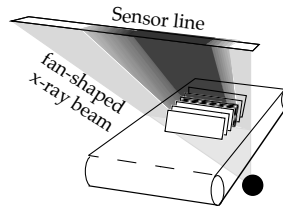

Figure 3.3b. Scanners with a sensor line scan the baggage slice by slice. Each slice is projected with point perspective, while all slices are scanned in a parallel direction.

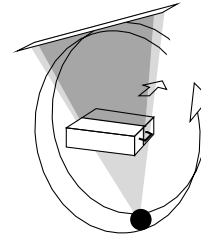

Figure 3.3c. CT scanners scan a large number of slices, using a source and sensor line rotating around the baggage. From these images a 3D reconstruction is made.

In the discussion of these three types of machines, a large number of scanners will be mentioned. Table 3.1 gives an overview of them (see also Macrae and Taverna, 1990). In the text, I will refer to the machine name.

Table 3.1. The x-ray scanners discussed in this section.

Machine name	Manufacturer	Sensors	Article	Image processing
Heimann GPA8014	Heimann Systems GmbH	fluorescent screen	Linkenbach & Stein (1981)	
SDS400/P	Isorad	fluorescent screen	Isorad (1987)	
Heimann 6040, 9080	Heimann Systems GmbH	sensor line	Heimann (1987)	Pseudocolouring for material identification
Heimann 10050EDS	Heimann Systems GmbH	sensor line	Heimann (1996)	As Heimann 6040; markers indicate suspicious items
Controllix-Vision	Europscan	sensor line	Europscan (1993)	Pseudocolouring for material identification
Vivid	Vivid Technologies Inc.	sensor line	Vivid (1990)	Pseudocolouring for explosives identification
Aisys 370B	Magal Security Systems	sensor line	Magal (1994)	Markers indicate suspicious items
Z-Scan	EG&G Astrophysics	sensor line	EG&G Astrophysics (1996)	Pseudocolouring for material identification; Gives side and bottom view of suitcase
Scanray	Scanray	double sensor line	Evans, Godber & Robinson (1994)	
CTX5000	InVision Technologies	CT scan	Invision (1997)	Pseudocolouring for detonator and explosives identification

### Scanners with a fluorescent screen

One way of making an x-ray image of a suitcase is by exposing the entire suitcase to x-rays and by converting the x-rays that went through the baggage to visible light with a fluorescent screen. Figure 3.4 shows an SDS 400/P, a commercial system which works this way. A glass plate containing lead has to be present between the fluorescent screen and the inspector, to screen him from radiation. The images on the fluorescent screen are similar to a normal perspective photograph, as if the x-ray source replaces the camera lens, and the fluorescent screen replaces the sensitive plate that is normally behind the lens. The SDS400/P allows the inspector multidirectional real-time viewing by rotation of the inspected object with a knob. Although scanners with a fluorescent screen are very fast in generating an x-ray image, none of the commercial machines with such a screen are designed for fast throughput.

An image on a fluorescent screen has a low light intensity due to the low amount of radiation that can be sent through the baggage. Furthermore, because the image will decay if the x-ray beam is turned off, such machines will require a constant exposure of the baggage to x-ray. This continuous exposure may give the baggage an unacceptable dose of x-rays. To avoid continuous exposure and to amplify the brightness of the image, some systems record the image on the fluorescent screen with a light-sensitive video camera, whose image is stored in computer memory. Figure 3.5 shows such a system, the Heimann GPA8014. Usually the video camera views the fluorescent screen via a mirror, to prevent x-rays that went through the fluorescent screen from hitting the video camera. Finally, the image is displayed on a monitor display (Linkenbach and Stein, 1981).

Such a system with fluorescent screen, mirror and camera has two disadvantages. First, it requires a large empty space between the fluorescent screen, the mirror and the camera, and space is expensive. Second, it is quite an indirect way of displaying an x-ray image, and will introduce additional noise and blur.

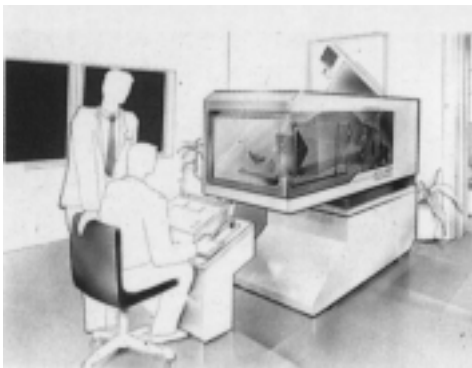

Figure 3.4. The SDS400/P, a machine using a fluorescent screen. Such machines give images with very low light intensity, and continuously expose the suitcase to x-rays.

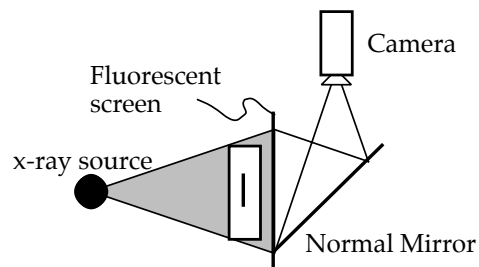

Figure 3.5. To improve light intensity and to shorten exposure time, the image can be recorded with a light-sensitive TV camera, stored in computer memory and displayed via a monitor.

### Scanners with a sensor line

In systems with a fluorescent screen, noise in the image is caused by the scattering of the x-rays by the baggage and the low contrast of the fluorescent screen. Image contrast can be improved and scanning noise reduced by scanning the baggage slice by slice instead of in one shot (Kotowski, 1986), as shown in Figure 3.3b. To accomplish this, a thin fan-shaped x-ray beam and a sensor line are required. The baggage is scanned slice by slice, and each scanned slice gives one line for the x-ray image. A conveyor belt moves the baggage through the scanner. The thinner the x-ray beam the sharper the image. Maharay (1989) reported that these fans have a thickness of about 5 mm. Current beams are even thinner than this. The need for a mirror and empty space can be avoided by using highly optimised x-ray sensors.

A further advantage of scanning the baggage line by line is that the scattered x-rays can be registered as such. The way the x-rays are scattered provides information about the materials in the baggage. In particular, the scattering characteristics of explosives may be of interest. If the whole suitcase were exposed at the same time, it would be much more difficult to determine what part of the baggage contains the material associated with to the scattering detected.

Because of these advantages over scanners with a fluorescent screen, most current x-ray scanners scan the baggage with a sensor line. This gives the typical x-ray scanner configuration as showed in Figure 3.6. The speed of the conveyor belt is usually 0.24 m/s (about 600 suitcases per hour). The belt of the Z-scan and of the HI-Scan 10065EDS (Heimann, 1996) have a speed of 0.5 m/s (up to 1500 suitcases per hour). Many systems allow the inspector to review the last few images, when in doubt after an earlier approval of a suitcase. Some systems can store all scanned images on a disk or tape. For example, the Aisys allows storage of a few hundred scans on a 525 Mb data tape. A complete scan gives the suitcase an x-ray dose between 0.9  $\mu\text{Sv}$  and 2  $\mu\text{Sv}$ . This allows for 10 (Heimann, 1987) or 25 (Europscan, 1993) scans to be made without exposing photographic films (1600 ASA) that may be in the baggage.

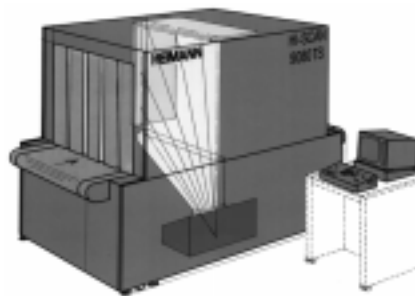

Figure 3.6. Exploded view of a typical x-ray scanner with sensor line. The x-ray source in the bottom of the machine sends a fan-shaped x-ray beam through the scanning tunnel. The sensor line is folded against the side of the tunnel.

The x-rays are sent through the baggage, and the baggage partly absorbs the x-rays. The amount of remaining x-rays is measured with the sensor line. The sensor line is often

folded, but the distortions caused by this folding can be compensated easily. Usually the sensor line contains between 576 and 2048 x-ray sensors. In most modern machines two x-ray sensors are used for one pixel in the final image. The analogue voltages coming from the detector array are digitised to 8 to 12 bit digital numbers, and combined in a computer to form the x-ray image. This gives images of up to 1280x1024 pixels, with up to 4096 grey levels per pixel (Europscan). Next to absorbing, the baggage also scatters the x-rays, so the tunnel and its entrance and exit hole are shielded with lead.

Some objects completely absorb x-rays, thus occluding objects lying behind them (a 'black hole'). The Z-scan (EG&G Astrophysics, 1996) solves this by making two images in instead of one, one side view and one bottom view. This bottom view may be used to see the objects that were hidden by the x-ray absorbing object. Figure 3.7 and 3.8 illustrate the principle. In stead of one x-ray beam, two fan-shaped x-ray beams are sent through the baggage. This will, of course, double the x-ray dose on the baggage. For another system, Evans, Godber and Robinson (1994) proposed displaying two such views stereoscopically. Scanray has been developing such a system (Wooley, 1986). For such a stereoscopic system the angle between the views has to be small. However, such a stereoscopic image does not enable the observer to look around an x-ray absorbing object.

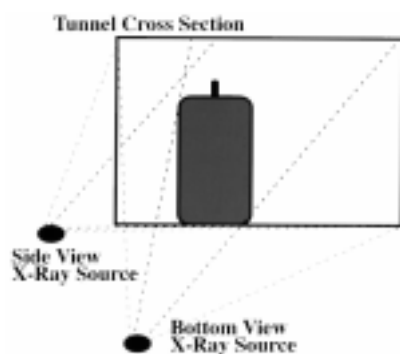

Figure 3.7. Cross section of a Z-scan by EG&G Astrophysics. This machine makes two scans of the baggage in one pass.

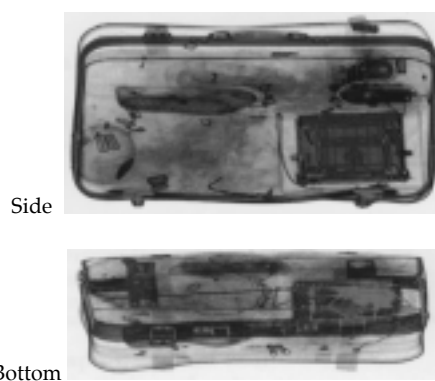

Figure 3.8 (see colour figure on left cover flap). Typical side and bottom view acquired with the Z-scan.

The sensor-line x-ray scanners mentioned above (Table 3.1) alter the raw x-ray images so that the information that is expected to be relevant for the inspector is emphasised. First, they increase the contrast in the image. Humans can distinguish up to about 256 grey levels in a monitor display, but to enhance the visibility of objects this range is usually limited to about 22 levels. A consequence of this contrast enhancement is that the inspector may have to adjust the contrast and brightness, depending on the part of the baggage he is inspecting. Second, most machines are able to magnify part of the image, to aid detailed inspection. For example the Heimann 9075 enables up to 16 times magnification of the image (Heimann, 1994).

Some machines provide information about the materials the suitcase contains. The Heimann machines distinguish organic, aluminium-like and metallic materials. This information is displayed by pseudo-colouring the grey-level image: organic parts are rendered orange, aluminium-like materials green and metallic parts blue (Figure 1.1 and

3.13; see also Heimann, 1997b). The Z-scan uses similar pseudo-colouring (Figure 3.8). The Vivid detects areas with a density close to the density of explosives, and pseudo-colours these areas red. The inspectors in the real-baggage experiment did not appreciate the pseudo-colouring of the Heimann 9075. The inspectors in that experiment suggested that the pseudo-colouring of the Heimann machines gives material information not relevant to their task.

Automatic recognition of suspicious shapes is of increasing importance. The Aisys automatically recognises parts of a detonator and places markers indicating those parts in the display (Figure 3.9). The Z-Scan places an ellipse around suspect areas (Figure 3.8).



Figure 3.9. Detail of an image from the Aisys 370B. An arrow (just above the B) indicates a suspect item.



Figure 3.10 (see colour figure on left cover flap). Image from the CTX5000. Red indicates possible explosives, green parts of a detonator.

### Computer Tomography scanners

A Computer Tomography (CT) scanner can make a 3D representation of the suitcase and its contents in computer memory. From this 3D representation, arbitrary views such as slices, perspective renderings and cut-through images, can be made. CT scanners are rarely used for baggage inspection because their use has practical problems. The CTX5000 (InVision, 1997) can scan 350 suitcases per hour, while scanners with a sensor line can scan up to 1500 bags per hour. Furthermore its 26-inch wide opening is too small for some baggage. The image resolution is 512x512 pixels, quite low compared to scanners with a sensor line. CT scanners have a complete x-ray scanner rotate around the baggage, and the reconstruction process requires a vast amount of calculation and computer storage, causing these machines to be bulky and expensive. Optimising strategies use 2D x-ray images to decide what part of the baggage needs more precise CT scans (Imatron, 1991, InVision & EG&G, 1997). A complete 3D reconstruction of the suitcase allows sophisticated object recognition. The CTX5000 tries to mark explosives and detonators with pseudocolouring (Figure 3.10).

### Conclusion

Currently, most baggage inspection is done with scanners using a sensor line. Such scanners provide a single high-resolution x-ray view of the baggage. These machines usually enhance the x-ray images with material information. The more recent machines also add markers indicating suspicious items.

Perceptual requirements for x-ray imaging are another important factor for the design of an x-ray baggage scanner. These perceptual requirements are discussed in the next section.



## What images are useful?

The question about the usefulness of particular views is difficult. All the experiments in this thesis deal with this question. However, as long as the baggage inspection task is not precisely operationalised no definitive answer can be given about the required visual and other information (see Chapter 1 and 2). In this section I will try to make a reasonable choice with the present knowledge and the results of the experiments described in Chapter 4-8. I start with choices about static image quality, number of views and the required viewpoints. Next, the perspective properties of the views are discussed. There are a large number of possibilities for the perspective, each having its own problems.

### What views and what quality?

I start with the easier choices, concerning image quality, number of images and required viewpoints. For static image quality it is necessary to consider the size of the critical objects. Consider the typical parts of a bomb: a battery, timing mechanism, detonator, explosives and wires. Visibility of wires up to 24 gauge (24 AWG = 0.5 mm Ø, Dorey, 1983) was required by the Federal Aviation Administration (FAA) (Tsacoumis, 1983). Currently, a resolution of 34 AWG (0.16 mm Ø) is usual. The timing mechanism can be extremely small, as a few transistors on a chip will suffice. Therefore, a timing mechanism can be invisible in x-ray images. The battery and detonator can be detected easily: typical detonators are cylindrical: about 5 cm long and 0.5 cm diameter. Batteries are usually also cylindrical, usually ranging from 0.5 to 5 cm long and 1 cm diameter. A number of articles suggest that 16 by 16 image pixels are sufficient to recognise an object. For example, face recognition is possible with the image of the face reduced to only 16 x 16 image pixels (Harmon, 1973) and aircraft silhouettes are reasonably identified with about the same number of pixels (Uttal, Baruch and Allen, 1995). Given the typical sizes of a battery and a detonator, about 15 x-ray sensors per cm seems reasonable for x-ray baggage inspection. For wire detection, fewer sensors per cm are sufficient: the Heimann 9075 has fewer than 5 x-ray sensors per cm and can detect up to 38 AWG (0.1 mm Ø). When multiple views are available, the results of the experiment described in Chapter 5 suggest that even fewer sensors per cm can be used.

For the required number of views, the complexity of the scene is important (see Chapter 6). I expect that the spatial scene complexity of real baggage lies somewhere between the spatial complexity of the connected objects scene and that of the knot tracing scene (see Chapter 2). Looking forward to Chapter 5 and 6, it is shown that, in the case of detecting wires connecting objects, observer performance does not increase with the number of views if more than two views are available. With the knot tracing task observer performance still increases with the number of views when 33 views are available. These results do not conclusively determine the required number of views, and therefore I attempted to determine the definitive number of views by an experiment with real baggage (Chapter 8). The results of the experiment with real baggage did not reveal an improvement of the inspector performance with more than two views, but several explanations for this result were proposed. Given the results of the experiments of Chapters 5 and 6, and given the maximum of about 25 x-ray photos to prevent damage of the baggage contents, providing 8 or 16 views seems reasonable.

One would expect that providing the inspector with information about the materials in the suitcase would help him to form his judgement. Furthermore a high resolution image would appear to be important for recognition of small objects such as wires, detonators and batteries. Given these arguments, an x-ray scanner with a sensor line looks a better choice than a scanner exposing the entire suitcase in one shot.

The Delft Virtual Window System can couple both left-right, forward-backward and up-down movements of the observer. However, making available views in all these degrees of freedom would require a huge number of x-ray photos. Not all these views are equally useful: for many tasks a small number of views in the horizontal arc is sufficient. The connected-objects task (Chapter 5) could be done reasonably well with a front and a side view. For the knot tracing task (Chapter 6) adding viewpoints in the vertical arc to the views in the horizontal arc did not result in a performance increase of the inspectors. Many experiments concerning movement parallax provide only horizontal freedom of movement of the observer (Rogers and Graham, 1979; Todd, Akerstrom, Reichel and Hayes, 1988; Cornilleau-Pérès and Droulez, 199). Bingham and Stassen (1994) discuss some evidence that forward-backward movements are also important for apparent depth, but they suggest that these movements make sense especially in the case of targeted actions. There are also theoretical grounds for choosing one degree of freedom: Braunstein, Hoffman, Shapiro, Andersen and Bennett (1987) indicate that if the scene rotates around a fixed axis, a 3D reconstruction of the scene can be made with fewer views than when the axis of rotation is variable. For ergonomic reasons, movement in the horizontal arc also is preferable over vertical movement: x-ray inspection is usually done while sitting behind the monitor, and horizontal head movements are less fatiguing than vertical movements (McVey, 1970). A single axis of rotation with a fixed angle between the views is also intuitive: it tells the observer about the available views and makes clear to the observer what to do to get a particular view. Furthermore, it makes replacement of viewpoint selection via eye position by viewpoint selection via a knob possible in an intuitive way. Finally, it is expected that a single axis of rotation will allow for easier technical constructions to shoot the images than when multiple axes of rotations have to be supported.

In conclusion, a reasonable choice is to use a scanner with a sensor line to shoot 8 or 16 views. The views should have only a horizontal degree of freedom, e.g. a vertical axis of rotation, and the angle between two views has to be approximately constant.

### **Perspective properties- static camera**

The perspective properties of x-ray images are quite complex. I start with two different perspective possibilities for a static x-ray image. Next, I will discuss two possible couplings between camera movement and image transformation. Both the static and the dynamic perspective transformation can be chosen independently for the horizontal and vertical direction of the image, giving a total of 16 possible perspective combinations. Finally, the consequences of these perspective combinations are discussed.

There are two aspects of the perspective properties of static x-ray images. First, a perspective can be either a convergent perspective (C perspective) or a parallel perspective (P perspective) (Figure 3.11). In these figures, the back of the suitcases will be shaded for clarity.

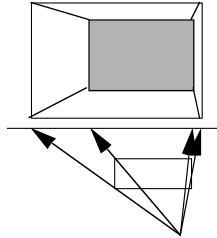

Figure 3.11a. With convergent (C) perspective the back of the suitcase is projected smaller than the front.

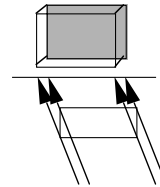

Figure 3.11b. With parallel (P) perspective, the front and the back of the suitcase are of equal size.

Second, the perspective can be different for the horizontal (H) and the vertical (V) direction in the image (Figure 3.12). Table 3.2 outlines the four possible perspective combinations for a static image. Combinations will be abbreviated, for example horizontal convergent perspective combined with vertical parallel perspective will be abbreviated as HC VP perspective. As a scanner with a sensor line always gives a convergent perspective in the direction of the sensor line, the HP VP perspective is of no interest in the present context.

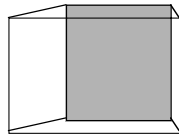

Figure 3.12a. With HC VP perspective the height of the front and back plane are equal, while the width of the front plane is greater than that of the back.

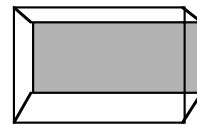

Figure 3.12b. With HP VC perspective the widths are equal, while the heights are different.

Table 3.2. Possible perspective properties for a static image. The shaded HP VP perspective combination is not relevant for scanners with a sensor line.

	Horizontal Convergent (HC)	Horizontal Parallel (HP)
Vertical Convergent (VC)		
Vertical Parallel (VP)		

X-ray images acquired with a scanner with a sensor line are images with a parallel perspective in one direction and a convergent perspective in the other direction. For example Figure 3.13, an image from a Heimann 6040-A, has HP VC perspective. In this figure, vertical convergent perspective suggests a viewpoint in the plane through the bottom of the baggage. The camera must be very close to the baggage, as the top of the suitcase is displayed almost perpendicular. However, both the left and right side of the image suggest a viewpoint in the plane through that side, indicating a camera position at infinity. Furthermore, such a combination of parallel and convergent perspective is almost never encountered in real life. Such conflicting cues may have perceptual consequences.

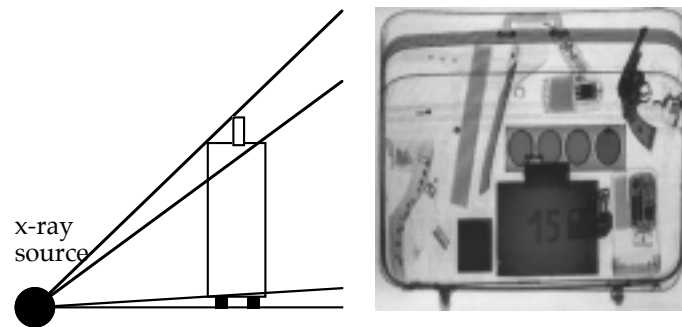

Figure 3.13. An image from a Heimann 6040-A (right) illustrates conflicting perspective. Vertically the image has convergent perspective and horizontally it has parallel perspective. The left figure shows the relation between the x-ray image and the edges of a real suitcase.

### Perspective properties- moving camera

I will now discuss what happens if the camera can move. As chosen in the previous section, camera movement will be restricted to the horizontal arc. In the vertical direction a fixed angular viewing height can be chosen (Figure 3.14).

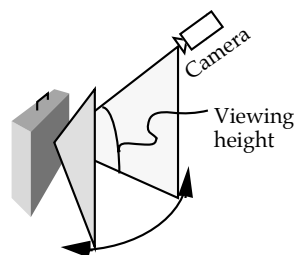

Figure 3.14. Camera movement is restricted to the horizontal arc. The angular viewing height is fixed.

A camera movement can result in a shear or in a rotation in the image (Figure 3.15). As with the parallel and convergent perspective, shear perspective (S) and rotational perspective (R) can be different for the horizontal and vertical direction in the image.

Again I will abbreviate, for example the combination of horizontal rotational perspective with vertical shear perspective is abbreviated as HR VS perspective.

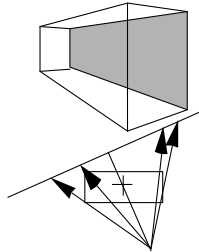

Figure 3.15a. With rotational perspective the projection plane always is perpendicular to the line from the camera through the centre of the suitcase

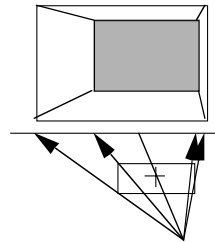

Figure 3.15b. With shear perspective the projection plane is always parallel to the suitcase.

Combined with the convergent and parallel perspective, Table 3.3 shows the possible *perspective combinations* for a moving camera.

Table 3.3. Possible perspective combinations for a moving camera. Terms are abbreviated, eg., the cell marked with '\*' is indicated with HRP VSC perspective. As in Table 3.2, the shaded fields are of no interest in the present context.

		Horizontal perspective (H)			
		Rotational (R)		Shear (S)	
		Conver- gent (C)	Parallel (P)	Conver- gent (C)	Parallel (C)
Vertical Perspec- tive (V)	Rotational (R)	Convergent Parallel			
	Shear (S)	Convergent Parallel		*	

The perspective combinations differ in appearance: some suggest a nonrigid deformation of the baggage (Figure 3.16). The goal is to minimise the disturbing perceptual effect by choosing an appropriate perspective combination. The next section discusses the perceptual effect of the possible perspective combinations and how the disturbing effect depends on particular viewpoints.

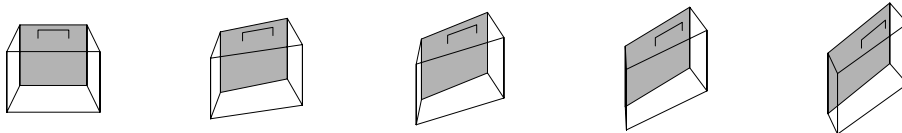

Figure 3.16. An unusual perspective combination may lead to images that suggest nonrigid deformations.

### Perceptual consequences of the perspective combinations

Little is known about the perceptual consequences of the possible perspective combinations of Table 3.3, although x-ray inspectors have been working with such images for years. In order to get an idea of the perceptual consequences of the perspective combinations, a simulation was made displaying a wire frame suitcase for several perspective combinations. In the next pages I show a series of views for each combination, and I describe my impression from the simulation. The simulated combinations were inspected both with the view being selected via head tracking and with the view being selected with a knob.

I chose the viewing distance to be twice the width of the suitcase. Looking from a viewing height slightly above the suitcase (see Figure 3.14) gives a less distorting depth impression than looking at a height of 0°. I will first discuss the perspective combinations when the viewing height is 45° (see Figure 3.14). A 25° viewing height reduces visibility of the top of the suitcase, and therefore seems to reduce disturbing visual effects. This 25° viewing height will be discussed next.

Figure 3.17 shows views from the perspective combinations with HR VR perspective. The first row shows images with HC VC perspective. These images look acceptable. With HP VC perspective (second row), the left and right side of the suitcase become a single line in front view. The protruding side of the suitcase distorts in these views. Perceptually, this is a highly disturbing effect. With HC VP perspective (last row), the suitcase seems to twist.

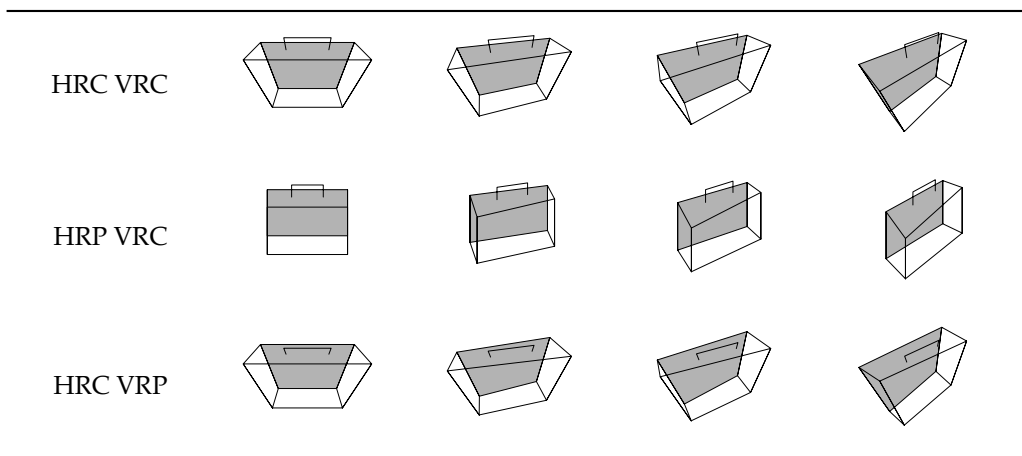

Figure 3.17. combinations with horizontal and vertical rotational (HR VR) perspective .

Figure 3.18 shows views from the perspective combinations with HR VS perspective. Images with HC VC perspective and with HP VC perspective (first and second row): here the views look acceptable. With HC VP perspective (last row), the front view is disturbing, as the heights of front and back of the suitcase are of equal height. The side views are unacceptably distorted: the sides rotate and stretch relative to each other.

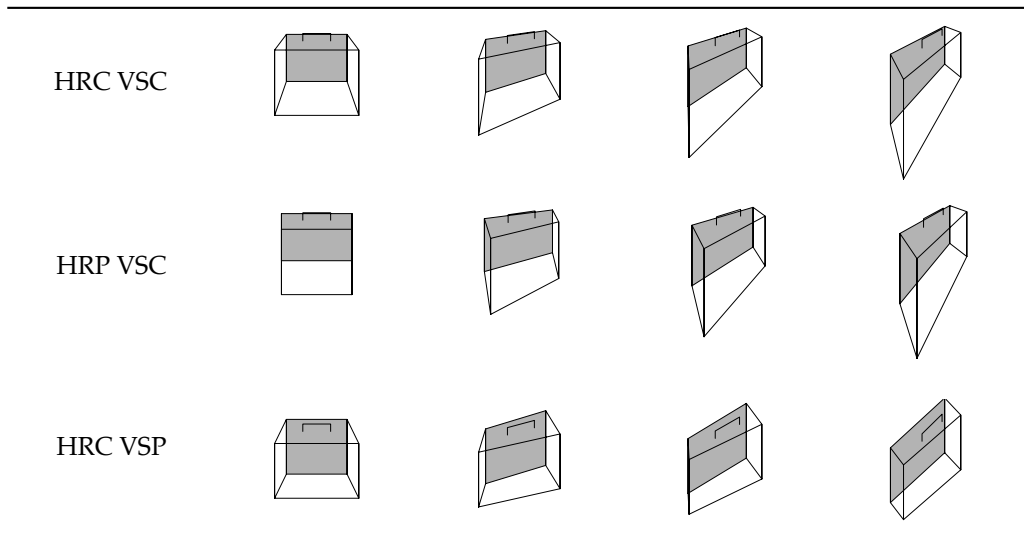

Figure 3.18. combinations with horizontal rotational and vertical shear (HR VS) perspective.

Figure 3.19 shows views with HS VR perspective. In the HC VC perspective combination (first row), the suitcase seems narrowed at the bottom. The second row shows images with HP VC perspective. The front and back of the suitcase are always of equal size. This is caused by the 45° height of the view, and is disturbing here as perceptually it suggests that the front is smaller than the back. When the viewpoint is selected manually rather than via eye position, depth reversal occurs. The last row shows the images with HC VP perspective. These images are highly distorted: the suitcase looks rotated backwards, larger at the top and smaller at the bottom. In these three cases, the baggage seems to shear if the viewpoint is selected by knob instead of by eye position.

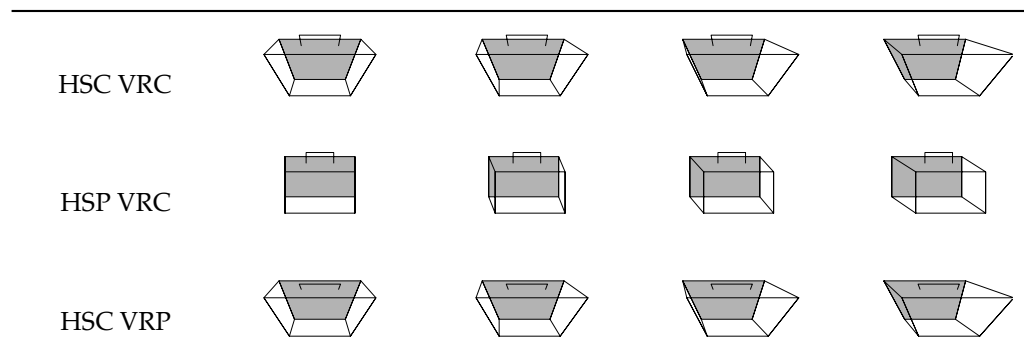

Figure 3.19. combinations with horizontal shear and vertical rotational (HS VR) perspective.

Figure 3.20 shows views with both horizontal and vertical shear perspective. With both HC and VC perspective, there is no apparent distortion when eye position is coupled

accurately. Note that this combination is a perfect off-axis coupling (see Chapter 7). With HP VC perspective, the back of the baggage seems wider than the front, while with HC VP perspective the back looks higher than the front. Again, in these three cases the suitcase seems to shear if the viewpoint is selected manually instead of via eye position.

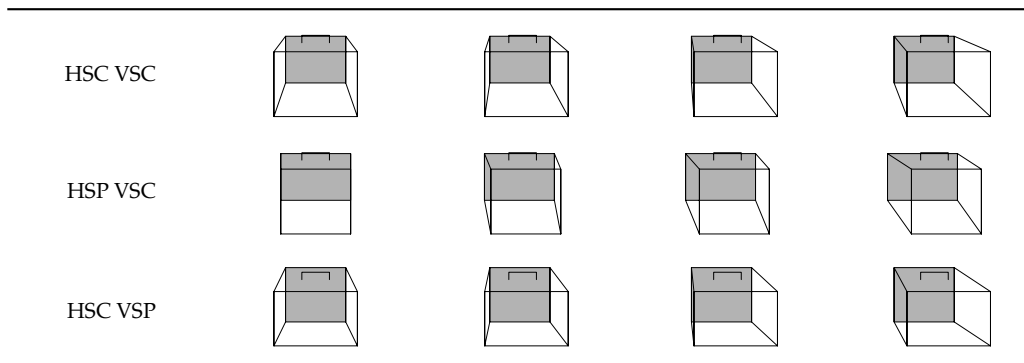

Figure 3.20. Combinations with horizontal and vertical shear (HS VS) perspective.

A number of situations can be improved by reducing the viewing height (see Figure 3.14), so that the top of the suitcase reduces almost to a single line. A viewing height of 25° instead of 45° will achieve this. Three of the perspective combinations discussed above benefit from a lower view: the HRP VRC perspective, the HRC VSP perspective and the HSP VRC perspective combinations. Figure 3.21 shows views in these perspective combinations for a viewing height of 25°.

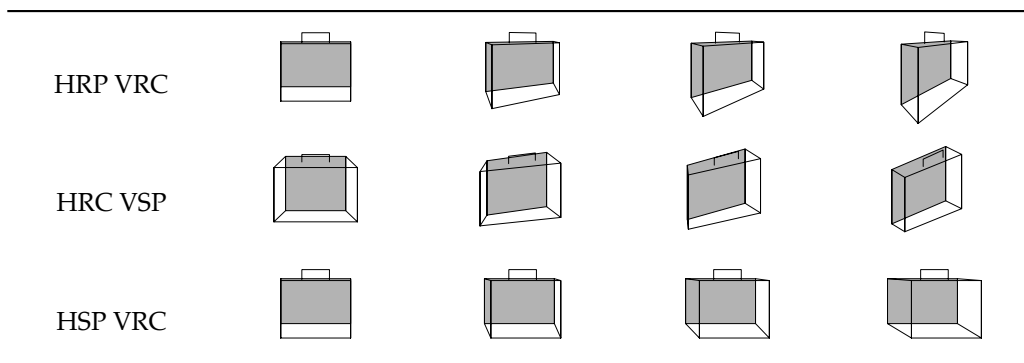

Figure 3.21. Three perspective combinations with 25° top view instead of 45°. These conditions show lower distortion with this lower view.

With 25° viewing height, the HRP VRC perspective combination (first row) looks very much like the HRP VSC perspective with a viewing height of 45° (Figure 3.18), and looks acceptable. In the HRC VSP combination (second row) the nonrigid distortions are smaller than with 45° viewing height, but they are still disturbing. For the HSP VRC perspective combination (third row) the images look similar to the HSP VSC combination at a viewing height of 45° (Figure 3.20), and just as acceptable.



## Discussion and conclusions

The perceived distortions in the combinations with horizontal shear perspective may be explained as follows. The observer is forced to use perspective cues because many other cues are absent. Similarly, in x-ray baggage inspection perspective cues may be important because with x-ray images several cues, such as shading, occlusion and shadows, are absent. As is discussed in Chapter 7, the perspective determines the geometrically appropriate (geometrically equivalent) viewpoint, and for horizontal shear perspective this viewpoint moves with the amount of shear. This explains the apparent distortions if the viewpoint is selected manually instead of via eye position. The distortions apparent with horizontal shear and viewpoint selection via eye position can also be explained with geometry. It can be shown that the geometrically appropriate perspective is HSC VSC perspective (called on-axis coupling in Chapter 7). This perspective is equivalent to a scaling of the objects in the scene by their distance from the observer, followed by HSP VSP perspective, with the shear depending on the viewing position of the observer. When the amount of shear is coupled correctly, *any* perspective combination is geometrically consistent both over different viewpoints, but the apparent scene is deformed. The observer can see only the consistency, and this may suggest to the observer that the perspective cues are reliable, and he therefore does an inverse object scaling, with the distance of objects from the observer extracted from the amount of shear. This explains why objects appear too large in the horizontal or vertical direction when this direction is not scaled according to the distance from the object to the observer, and why the scene looks deformed when vertical rotation instead of vertical shear is used. The distortions noticed with horizontal rotational perspective can not be explained so 'easily'.

Technical requirements were proposed indicating what images are useful for baggage inspection. A reasonable choice is to use a scanner with a sensor line to shoot 8 or 16 views. The views should have only a horizontal degree of freedom, e.g. a vertical axis of rotation, and the angle between two views has to be approximately constant.

The choice for the perspective combination proved to be more difficult. The most important result is that horizontal shear perspective will result in nonrigid deformations if the view is not selected via eye position. With horizontal rotational perspective, perspective combinations with both horizontal and vertical convergent perspective look acceptable. Furthermore the combination with vertical shear, horizontal parallel and vertical convergent perspective looks acceptable. Viewpoint selection via a knob and via eye position do not differ here. Some combinations giving a distorted impression look acceptable when viewed from such a height that the camera is approximately in the plane through the top of the suitcase. However, the choice for the perspective combination also depends on the motion mechanism, which is discussed in the next section. Afterwards, in 'Optimised concepts', the diverse requirements are combined into an optimal choice. The next section uses the technical requirements and perceptual consequences discussed in this section to make an appropriate technical concept for acquiring multiple x-ray views.

## Mechanisms

This section integrates the partial analyses of the previous section into proposed mechanisms for shooting multiple x-ray images. There are a large number of possible mechanisms to shoot such images, and I start with an outline of the possibilities. Next, the requirements of the previous section are used to choose two technical concepts. These concepts are worked out in more detail. Finally a construction is described that was used for shooting the images for the real-baggage experiment.

### Outline of possibilities

There are a large number of ways of making multiple x-ray images. First, there is a choice between moving the baggage, moving the x-ray source or moving the sensor line to obtain a different view (Figure 3.22). In these three concept solutions the baggage is translated through the fan-shaped x-ray beam, as in conventional baggage inspection. This means that the conveyor belt has to be reversed for each new x-ray view of the suitcase.

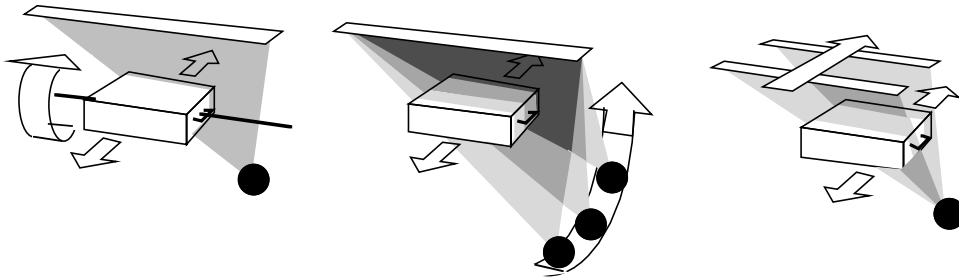

Figure 3.22. Three methods of obtaining different views. For each view, the x-ray image is taken by translating the suitcase through a static fan-shaped x-ray beam. To obtain the next viewpoint, the suitcase can be rotated (left), the x-ray source can be moved (middle) or the sensor line can be moved (right).

Second, there is a choice whether this movement to obtain the appropriate viewpoint involves a rotation around an axis in the plane of the fan-shaped beam or around an axis perpendicular to this plane (Figure 3.23). Third, a linear or rotational movement of the x-ray source or sensor line can be chosen (Figure 3.24). Even more complex movements may be used.

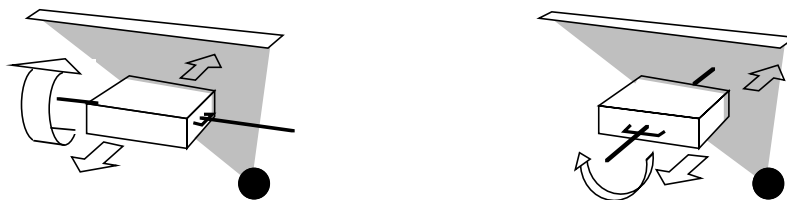

Figure 3.23. To acquire an appropriate view, the baggage can be rotated either around an axis parallel to the fan-shaped x-ray beam (left) or around an axis perpendicular to that beam (right).



Figure 3.24. The movement of the x-ray source or sensor line can be a translation (left) or a rotation (right).

Fourth, movements of Figure 3.22, 3.23 and 3.24 may be combined, giving a huge number of concepts for acquiring multiple views. Figure 3.25 shows an example. Finally, a movement of the x-ray source or sensor may be replaced by multiple stationary sources or sensors (Figure 3.26).

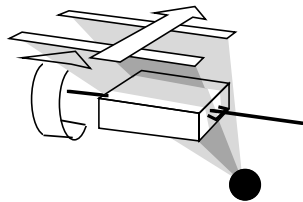

Figure 3.25. Movements can be combined. Here, a translating line scanner scans one view. For the next view, the baggage is rotated and scanned again.

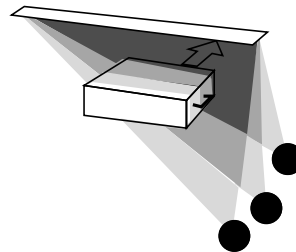

Figure 3.26. Instead of moving the x-ray source, multiple sources can be used. Here, the sources are alternated rapidly while the baggage is translated through their beams.

### Acquiring multiple views with a conventional scanner

For finding the precise number of views required, an experiment was done with real x-ray images and real baggage inspectors (Chapter 8). The required x-ray images were taken from a standard scanning machine (a Heimann 9075, similar to Figure 3.6). As the source and sensor line are fixed in such a machine, it was necessary to rotate the baggage. I chose to use the parallel perspective in the horizontal direction, and the convergent perspective in the vertical direction, because the distortions this combination gives can be made acceptable by choosing a 25° top view of the suitcase (see 'Perceptual consequences of the perspective combinations' in the previous section). The alternative, parallel perspective in the vertical direction and convergent perspective in the horizontal direction, will show less improvement with a 25° top view of the suitcase. A foam construction was made (Figure 3.27) that allowed rotation of the baggage over 90°. Polystyrene foam is nearly invisible in an x-ray image, and thus could be used to hold the suitcase. The foam was covered with paper to prevent damage.

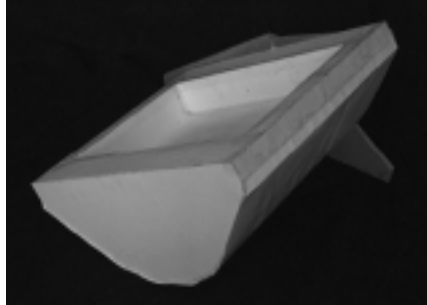

Figure 3.27. Foam construction that allows suitcases to rotate between  $-45^\circ$  and  $+45^\circ$ . This construction was used to make x-ray images of real baggage (see Chapter 8).

### Criteria for selecting a concept

The foam construction of Figure 3.27 worked well with an existing scanner, but scanning 16 views is time consuming (more than 10 minutes), and requires manual rotation of the baggage. Therefore this concept is not effective to use in a commercial machine. The criteria that the users and manufacturers will consider are discussed below.

The first criterion is the perspective combination. The perspective cues in the image should not disturb the inspector. The perspective properties of the scanned images are determined by the orientation of the sensor line relative to the baggage and the way baggage, sensor line and source are moved. The perceptual consequences of the perspective properties were discussed in the previous section, and can be used to select a concept solution.

Another criterion is scanning speed. Some of the technical concepts are able to take multiple x-ray images in one pass of the suitcase (e.g. Figure 3.26), while other concepts require multiple passes (e.g. Figure 3.23) or halting the conveyor belt (e.g. Figure 3.25). As each image takes the conventional scan time, taking 16 images (the number I expected to be useful; see previous section) with the reversing belt strategy (Figure 3.23) would take 16 times the conventional scan time, which seems unacceptable. Stopping the belt may be acceptable, if not for too long and if stopping the belt gives no conflict with the other conveyor belts in the baggage inspection system.

A third criterion concerns reliability. For example, given the uncertainties about baggage weight and size, it seems not a good idea to rotate the baggage. Furthermore, due to the gravity the baggage contents may move if the baggage is rotated, and this would give useless images. Baggage contents may also move if the belt has to be reversed a number of times. X-ray sources may be hard to move, because they are heavy, but their movement may be simulated by moving an x-ray mirror.

Finally, the costs of implementing the concept have to be considered. Because sensor lines are expensive, it does not seem a good idea to make an array of 1000 sensor lines to shoot the image in a single pass. Concepts with more than 16 sensor lines would be extremely expensive to implement.

### Chosen concepts

The criteria described above were used to select a number of concept solutions from the huge number of possible concepts for acquiring multiple views. Figure 3.28 shows the first concept solution. The baggage stops at the required position for the view. Next, the x-ray view is made by translating the sensor line over the baggage (the slit in the source has to move accordingly, in order to keep the beam aimed at the sensor line). Then the baggage is transferred to the next position by the conveyor belt. After 16 iterations the required 16 views are attained. The second concept (Figure 3.29) transfers a mirror in stead of the sensor line. Again, the baggage stops at the required position for the next view. The x-ray view is made by translating the x-ray mirror under the suitcase. This is repeated until the required number of views have been made. The varying distance between the x-ray source and sensor line, caused by the movement of the mirror away from the x-ray source, may give perspective distortions besides those resulting from the perspective combination.

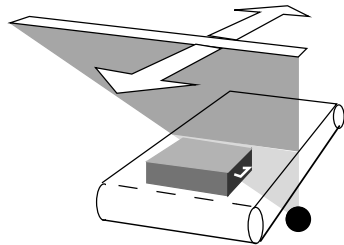

Figure 3.28. First concept solution. A single view is scanned by translating the sensor line over the suitcase. For the next view, the suitcase is translated to the next viewpoint by the conveyor belt.

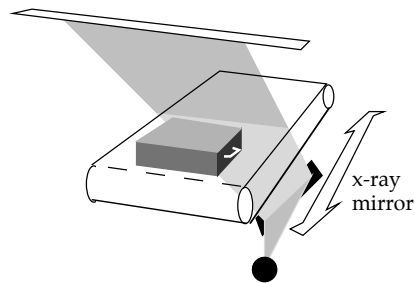

Figure 3.29. Second concept solution. A single view is scanned by translating the x-ray mirror under the suitcase. For the next view, the suitcase is translated to the next viewpoint by the conveyor belt.

Both the above concepts require the conveyor belt to be stopped for each x-ray view. This causes delays and the baggage contents may be disturbed by changing the speed of the suitcases. The next three concepts solve these problems by using multiple sources or sensors. Figure 3.30 shows such a concept. The conveyor belt just moves the baggage through the x-ray fans.

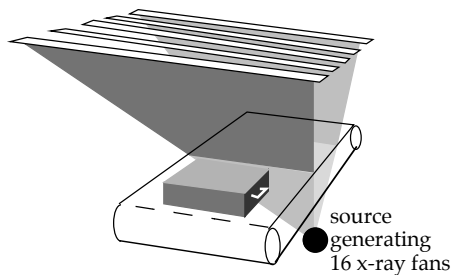

Figure 3.30. Concept that allows continuous throughput of the baggage. The source generates 16 fan-shaped beams, each giving a different view of the baggage.

### Optimised concepts

Figure 3.31 shows a concept similar to Figure 3.30, but price-optimised. A combination of 4 sources and 4 sensor lines will cost about NLG 100,000 (USD 50,000) which is cheaper than a configuration with 1 source and 16 sensor lines, which will cost about NLG 150,000 (USD 75,000). The idea of this concept is that the four sources are turned on and off rapidly after each other, each exposing the four sensor lines, giving a total of 16 views. Again, the conveyor belt just moves the baggage through the pulsating x-ray fans. Rapidly turning x-ray sources on and off seems no problem: just switching the voltage between the anode and cathode should suffice. As with the previous concept, this line scanner provides images with horizontal shear perspective.

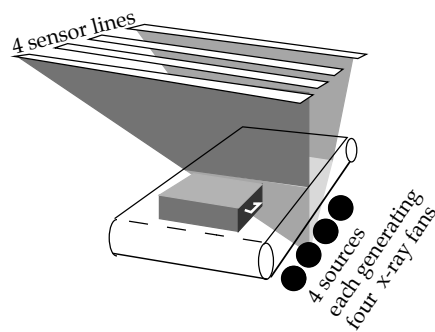

Figure 3.31. Price-optimised concept. Each of the four sources in turn generates four fan-shaped beams, giving in total 16 views. The absence of moving parts other than the conveyor belt makes the mechanism reliable.

Figure 3.32 shows a concept giving an image perspective with horizontal rotation in stead of shear. One x-ray source exposes the x-ray mirrors one after the other. The x-ray sources reflect the x-rays to the single sensor line. This way, the mirrors multiply the single real source into a number of virtual sources. To acquire 16 views, 16 mirrors are required. The conveyor belt just moves the suitcase through reflected x-ray fans. It seems possible to make the required x-ray source by rapidly rotating a lead shield with a slit around the x-ray source.

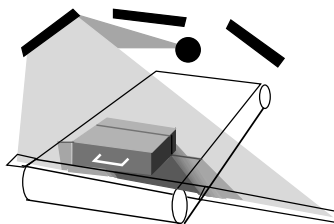

Figure 3.32. Concept giving views with horizontal rotation in stead of horizontal shear. The x-ray source exposes the x-ray mirrors one after another. In total 16 such mirrors are required to get 16 views. Only 3 are shown.

I will concentrate on the last two solutions, because they contain few or no moving parts, allowing for high reliability. Consider the concept with both multiple sources and multiple sensors (Figure 3.31). The sources and sensors can be placed at arbitrary places along the conveyor belt. The precise source and sensor positions have to be selected so that there is an equal angular distance between the acquired views. Finding a setup with exactly the same angle between the views is a hard mathematical problem, but I found a number of close solutions. One of these is shown in Figure 3.33. The precise height of the suitcase between the sources and sensor lines is important only for the required viewing angle, and can be chosen freely. Figure 3.34 shows the shear of each view (in radians), and it can be seen that the views are spread quite evenly over the viewing range. This concept will provide images with horizontal shear perspective. Therefore the acquired images should be coupled to the eye position of the inspector, but the images are not suitable for selection by a knob (see discussion under 'Perceptual consequences of the perspective combinations' in the previous section). The distance from source to suitcase is not constant, but this is geometrically appropriate (see also Chapter 7).

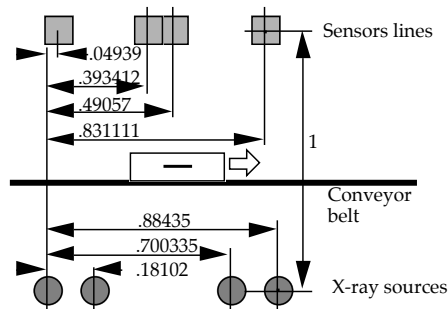

Figure 3.33. Side view of a configuration with 4 sources and 4 sensors, optimised to give an equal angle between the acquired views. Numbers indicate lengths.

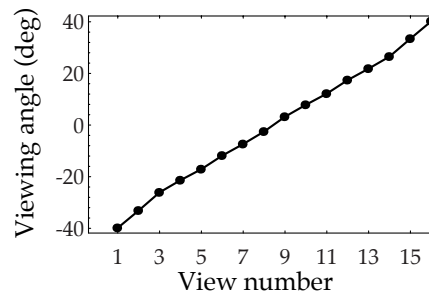

Figure 3.34. Viewing angle of the views acquired with the configuration of Figure 3.33.

The concept with x-ray mirrors (Figure 3.32) gives images with horizontal rotational perspective in stead of shear perspective . This concept is worked out in more detail in Figure 3.35. Care has to be taken that the x-ray mirrors do not overlap and that the total distance from the source via the mirror to the suitcase remains constant. The image perspective will have horizontal rotational convergent perspective and vertical shear parallel perspective. This means that these images can be presented with viewpoint selection by a knob instead of via the eye position of the observer. As x-ray mirrors are not a standard product, I am unable to estimate how much x-ray mirrors would cost. Using multiple x-ray sources may be cheaper than using x-ray mirrors.

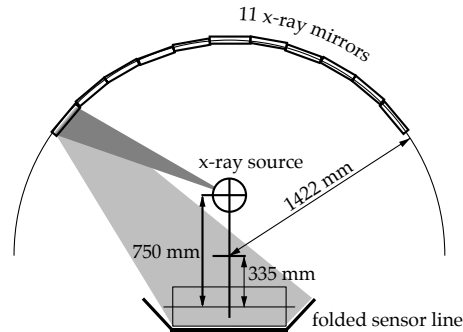

Figure 3.35. Cross-section of a configuration with x-ray mirrors. The mirrors and the sensor line are in a single plane; the x-ray source hangs 750mm in front of this plane. The total distance from the source to the centre of the suitcase is the same for all 11 views.

## Conclusions

A number of concepts were proposed, considering technical possibilities, perspective properties and their perceptual consequences, price and scanning speed. The perceptual consequences of the possible perspective combinations had to be estimated, because of a lack of theoretical and experimental knowledge.

Two concepts were worked out in more detail. The proposed mechanism with multiple sources and sensors is feasible, both technically, perceptually and in terms of price. However, its images have horizontal shear perspective, where a horizontal rotational perspective is preferable. To obtain horizontal rotational perspective another concept using multiple x-ray mirrors was proposed. The price of x-ray mirrors is uncertain, but multiple sources can replace the mirrors. Although more expensive than the mechanism with multiple sources and multiple sensors, this concept still seems feasible, perceptually, technically and in terms of price.

As I have no evidence that the DVWS can improve the performance of baggage inspectors (Chapter 8), no manufacturer of x-ray machines was approached to build a prototype of a multiple-view x-ray scanner. Therefore, no technical drawings were made and no precise components were selected for the proposed concepts.