

See discussions, stats, and author profiles for this publication at: <https://www.researchgate.net/publication/30499434>

# Compositional Verification of a Multi-Agent System for One-to-Many Negotiation

Article in *Applied Intelligence* · July 2002

DOI: 10.1023/B:APIN.0000013334.33853.0c · Source: OAI

CITATIONS

16

READS

70

7 authors, including:



**Frances M.T. Brazier**

Delft University of Technology

343 PUBLICATIONS 3,391 CITATIONS

[SEE PROFILE](#)



**Frans Cornelissen**

Johnson & Johnson

48 PUBLICATIONS 1,228 CITATIONS

[SEE PROFILE](#)



**Rune Gustavsson**

KTH Royal Institute of Technology

102 PUBLICATIONS 764 CITATIONS

[SEE PROFILE](#)



**Catholijn M. Jonker**

Delft University of Technology

541 PUBLICATIONS 6,270 CITATIONS

[SEE PROFILE](#)

Some of the authors of this publication are also working on these related projects:



Modeling Human Empathy and Empathic Social Interaction [View project](#)



Computational analysis of social effects in energy trading in rural India [View project](#)

# Compositional Design and Verification of a Multi-Agent System for One-to-Many Negotiation

Frances Brazier<sup>1</sup>, Frank Cornelissen<sup>1</sup>, Rune Gustavsson<sup>2</sup>, Catholijn M. Jonker<sup>1</sup>,  
Olle Lindeberg<sup>2</sup>, Bianca Polak<sup>1</sup>, Jan Treur<sup>1</sup>

<sup>1</sup>*Vrije Universiteit Amsterdam*

*Department of Mathematics and Computer Science, Artificial Intelligence Group  
De Boelelaan 1081a, 1081 HV Amsterdam, The Netherlands*

URL: <http://www.cs.vu.nl/{frances,frankc,jonker,treur}> Email: {frances,frankc,jonker,treur}@cs.vu.nl

<sup>2</sup>*University of Karlskrona/Ronneby (HK/R)*

*Department of Computer Science and Business Administration, Research Laboratory SIKT*

URL: <http://www.sikt.hk-r.se> Email: {Rune.Gustavsson, Olle.Lindeberg}@ide.hk-r.se

## Abstract

*A compositional verification method for multi-agent systems is presented and applied to a multi-agent system for one-to-many negotiation in the domain of load balancing of electricity use. Advantages of the method are that the complexity of the verification process is managed by compositionality, and that parts of the proofs can be reused in relation to reuse of components.*

## 1. Introduction

When designing multi-agent systems, it is often difficult to guarantee that the specification of a system actually fulfils the needs, i.e., whether it satisfies the design requirements. Especially for critical applications, for example in real-time domains, there is a need to prove that the designed system has certain properties under certain conditions (assumptions). While developing a proof of such properties, the assumptions that define the bounds within which the system will function properly, are generated. For nontrivial examples, verification can be a very complex process, both in the conceptual and computational sense. For these reasons, a recent trend in the literature on verification is to exploit compositionality and abstraction to structure the process of verification; cf. [1], [11], [12].

The development of structured modelling frameworks and principled design methods tuned to the specific area of multi-agent systems is currently underway; e.g., [5], [9], [13]. Mature multi-agent system design methods should include a verification approach. For example, in [9] verification is addressed using a temporal belief logic. In the approach presented below, a compositional verification method for multi-agent systems (cf. [12]) is used for formal analysis of a multi-agent system for one-to-many negotiation, in particular for load balancing of electricity use; see [4]. In short, the properties of the whole system are established by derivation from assumptions that themselves are properties of agents, which in turn may be derived from assumptions on sub-components of agents,

and so on. The properties are formalised in terms of temporal semantics. The multi-agent system described and verified in this paper has been designed using the compositional development method for multi-agent systems DESIRE; cf. [5].

## 2. Compositional Verification

The purpose of verification is to prove that, under a certain set of conditions (assumed properties), a system will adhere to a certain set of desired properties, for example the design requirements. In the compositional verification approach presented in this paper, this is done by a mathematical proof (i.e., a proof in the form mathematicians are accustomed to do) that the specification of the system together with the assumed properties implies the properties that it needs to fulfil.

### 2.1. The Compositional Verification Method

A compositional multi-agent system can be viewed at different levels of process abstraction. Viewed from the top level, denoted by  $\perp_0$ , the complete system is one component  $s$ ; internal information and processes are hidden. At the next, lower level of abstraction, the system component  $s$  can be viewed as a composition of agents and the world. Each agent is composed of its sub-components, and so on. The compositional verification method takes this compositional structure into account. Verification of a composed component is done using:

- properties of the *sub-components* it embeds,
- the way in which the component is composed of its sub-components (the *composition relation*),
- *environmental properties* of the component (depending on the rest of the system, including the world)

Given the specification of the composition relation, the assumptions under which the component functions properly are the environmental properties and the properties to be proven for its sub-components. This implies that properties at different levels of process

abstraction are involved in the verification process. The primitive components (those that are not composed of other components) can be verified using more traditional verification methods. Often the properties involved are not given at the start: to find them is one of the aims of the verification process.

The verification proofs that connect properties of one process abstraction level with properties of the other level are compositional in the following manner: any proof relating level  $i$  to level  $i+1$  can be combined with any proof relating level  $i-1$  to level  $i$ , as long as the same properties at level  $i$  are involved. This means, for example, that the whole compositional structure beneath level  $i$  can be replaced by a completely different design as long as the same properties at level  $i$  are achieved. After such a modification only the proof for the new component has to be provided. In this sense the verification method supports reuse of verification proofs. The compositional verification method can be formulated as follows:

### A. Verifying one Level Against the Other

For each abstraction level the following procedure for verification is followed:

1. Determine which properties are of interest (for the higher level).
2. Determine which assumed properties (at the lower level) are needed to guarantee the properties of the higher level, and which environment properties.
3. Prove the properties of the higher level on the basis of these assumed properties, and the environment properties.

### B. Verifying a Primitive Component

For primitive components, verification techniques can be used that are especially tuned to the type of component; both for primitive knowledge-based components and non-knowledge-based components (such as databases or optimisation algorithms) techniques (and tools) can be found in the literature.

### C. The Overall Verification Process

To verify the entire system

1. Determine the properties that are desired for the whole system.
2. Apply **A** iteratively. In the iteration the desired properties of each abstraction level  $L_i$  are the assumed properties for the higher level.
3. Verify the primitive components according to **B**.

Notes:

- The results of verification are two-fold:
  - (1) Properties at the different abstraction levels.
  - (2) The logical relations between the properties of adjacent abstraction levels.
- process and information hiding limits the complexity of the verification per abstraction level.
- a requirement to apply the compositional verification method described above is the availability of an explicit specification of how the system description at an abstraction level  $L_i$  is composed from the descriptions at the lower abstraction level  $L_{i+1}$ ; the compositional development method for multi-agent systems DESIRE fulfils this requirement.
- in principle different procedures can be followed (e.g., top-down, bottom-up or mixed).

## 2.2. Semantics behind Compositional Verification

Verification is always relative to semantics of the system descriptions to be verified. For the compositional verification method, these semantics are based on compositional information states which evolve over time. In this subsection a brief overview of these assumed semantics is given.

An *information state*  $M$  of a component  $D$  is an assignment of truth values  $\{\text{true, false, unknown}\}$  to the set of ground atoms that play a role within  $D$ . The compositional structure of  $D$  is reflected in the structure of the information state. A more detailed formal definition can be found in [6]. The set of all possible information states of  $D$  is denoted by  $IS(D)$ .

A *trace*  $\mathcal{M}$  of a component  $D$  is a sequence of information states  $(M^i)_{i \in \mathbb{N}}$  in  $IS(D)$ . The set of all traces (i.e.,  $IS(D)^{\mathbb{N}}$ ) is denoted by  $Traces(D)$ . Given a trace  $\mathcal{M}$  of component  $D$ , the information state of the input interface of component  $C$  at time point  $t$  of the component  $D$  is denoted by  $state_D(\mathcal{M}, t, \text{input}(C))$ , where  $C$  is either  $D$  or a sub-component of  $D$ . Analogously,  $state_D(\mathcal{M}, t, \text{output}(C))$  denotes the information state of the output interface of component  $C$  at time point  $t$  of the component  $D$ .

## 3. One-to-many Negotiation Processes

In this section the application domain is briefly sketched, and the one-to-many negotiation process devised within this domain is presented.

### 3.1. Load Balancing of Electricity Use

The purpose of load management of electricity use is to smoothen peak load by managing a more appropriate distribution of the electricity use among consumers. Flexible pricing schemes can be an effective means to influence consumer behaviour; cf. [10]. The assumption behind the model presented in this paper is that, to acquire a more even distribution of electricity usage in time, consumer behaviour can be influenced by financial gain. Consumers are autonomous in the process of negotiation: each individual consumer determines which price/risk he/she is willing to take and when. As consumers are all individuals with their own characteristics and needs (partially defined by the type of equipment they use within their homes), that vary over time, models of consumers used to design systems to support the consumer, need to be adaptive and flexible (cf. [2]). Utility companies negotiate price in a one-to-many negotiation process with each and every individual separately, unaware of the specific models behind such systems for individuals. In the model discussed in this paper the negotiation process is modelled for one utility company and a number of consumers, each with their own respective agent to support them in the negotiation process: one Utility Agent and a number of Customer Agents.

### 3.2. Modelling the Negotiation Process

In [14], [15] a number of mechanisms for negotiation are described. A protocol with well-defined properties, called the *monotonic concession protocol*, is described: during a negotiation process all proposed deals must be equally or

more acceptable to the counter party than all previous deals proposed. The strength of this protocol is that the negotiation process always converges. The monotonic concession protocol has been applied to the load management problem, to obtain a model for the one-to-many negotiation process between one Utility Agent and a (in principle large) number of Customer Agents.

In this model, the Utility Agent always initiates the negotiation process, as soon as a coming peak in the electricity consumption is predicted. In the method used the Utility Agent constructs a so-called *reward table* and communicates this table to all Customer Agents (*announcement*). A reward table (for a given time interval) consists of a list of possible cut-down values, and a reward value assigned to each cut-down value. The cut-down value specifies an amount of electricity that can be saved (expressed in percentages) and the reward value specifies the amount of reward the Customer Agent will receive from the Utility Agent if it lowers its electricity consumption by the cut-down value. A Customer Agent examines and evaluates the rewards for the different cut-down values in the reward tables. If the reward value offered for the specific cut-down is acceptable to the Customer Agent, it informs the Utility Agent (*bid*) that it is prepared to make a cut-down  $x$ , which may be zero to express that no cut-down is offered.

As soon as the Customer Agents have responded to the announcement of a reward table, the Utility Agent predicts the new balance between consumption and production of electricity for the stated time interval. The Utility Agent is satisfied by the responses if a peak can be avoided if all Customer Agents implement their bids. If the Utility Agent is not satisfied by the responses communicated by the Customer Agents, it announces a new reward table (according to the monotonic concession protocol mentioned above) to the Customer Agents in which the reward values are at least as high, and for some cut-down values higher than in the former reward table (determined on the basis of, for example, the formulae described in Section 4.2 below). The Customer Agents react to this new announcement by responding with a new bid or the same bid again (in line with the rules of the monotonic concession protocol). This process continues until (1) the peak is satisfactorily low for the Utility Agent (at most the capacity of the utility company), or (2) the reward

values in the new reward table have (almost) reached the maximum value the Utility Agent can offer. This value has been determined in advance. For more details on this negotiation method, see [4].

## 4. Compositional Design of the System

The prototype Multi-Agent System has been fully specified and (automatically) implemented in the DESIRE software environment. The top level composition of the system consists of a Utility Agent, two Customer Agents, and an External World.

### 4.1. Top Level Composition of the Utility Agent

The first level composition within the Utility Agent is depicted in Figure 1 (taken from the graphical design tool within the DESIRE software environment). This picture shows part of the graphical interface of the DESIRE software environment; in addition, interfaces to the agents have been implemented which are specific for this prototype (see [4]).

### 4.2. Knowledge used within the Utility Agent

In this prototype system the Utility Agent communicates the same announcements to all Customer Agents, in compliance with Swedish law. The predicted balance between the consumption and the production of electricity, is determined by the following formulae (here CA is a variable ranging over the set of Customer Agents):

$$\begin{aligned} \text{predicted\_use\_with\_cutdown}(CA) &= \\ &\text{predicted\_use}(CA) \\ &\quad \text{if } (1 - \text{cutdown}(CA)) \cdot \text{allowed\_use}(CA) \geq \text{predicted\_use}(CA) \\ &\quad (1 - \text{cutdown}(CA)) \cdot \text{allowed\_use}(CA) \\ &\quad \text{otherwise} \\ \text{predicted\_overuse} &= \\ &\sum_{CA} \text{predicted\_use\_with\_cutdown}(CA) - \text{normal\_use} \\ \text{overuse} &= \\ &\text{predicted\_overuse}/\text{normal\_use} \\ \text{new\_reward} &= \\ &\text{reward} + \beta \cdot \text{overuse} \cdot (1 - \text{reward}/\text{max\_reward}) \cdot \text{reward} \end{aligned}$$

Figure 1 Process composition at the first level within the Utility Agent

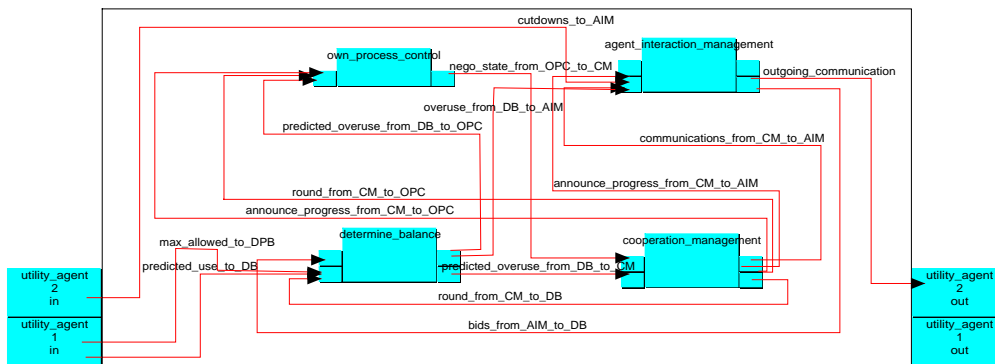

In the prototype system, the factor  $\beta$  determines how steeply the reward values increase; in the current system it has a constant value. The reward value increases more when the predicted overuse is higher (in the beginning of the negotiation process) and less if the predicted overuse is lower. It never exceeds the maximal reward, due to the logistic factor  $(1 - \text{reward}/\text{max\_reward})$ .

## 5. Verification at the Top Level

Two important assumptions behind the system are: energy use is (statistically) predictable at a global level, and consumer behaviour can be influenced by financial gain. These assumptions imply that if the financial rewards (calculated on the basis of statistical information) offered by a Utility Agent are well chosen, Customer Agents will respond to such offers and decrease their use.

The most important properties to prove for the load balancing system  $S$  as a whole are that (1) the negotiation process satisfies the monotonic concession protocol, (2) at some point in time the negotiation process will terminate, and (3) the agents make rational decisions during the negotiation process. These properties are formally defined in Section 5.1. An important property for the Utility Agent, in particular, is that after the negotiation process the predicted overuse has decreased to such an extent that is at most the maximal overuse the utility company considers acceptable. To prove these properties several other properties of the participating agents (and the external world) are assumed. These properties of agents and the external world are defined in Section 5.2. Some of the proofs of properties are briefly presented in Section 5.3. Next, Section 6 shows how these assumed properties can be proven from properties assumed for the sub-components of the agents.

### 5.1 Properties of the System as a Whole

The properties defined at the level of the entire system are based on combinations of properties of the agents.

#### S1. Monotonicity of negotiation

The system  $S$  satisfies *monotonicity of negotiation* if the Utility Agent satisfies monotonicity of announcements and each Customer Agent satisfies monotonicity of bids. This is formally defined as the conjunction of the Utility Agent announce monotonicity property U7 and for each Customer Agent the bid monotonicity property C5 (see below).

#### S2. Termination of negotiation

The system  $S$  satisfies *termination of negotiation* (on a given time interval) if a time point exists after which no announcements or bids (referring to the given time interval) are generated by the agents. This is formally defined by: for all Customer Agents CA it holds

$$\forall \mathcal{M} \in \text{Traces}(S) \exists t \forall t' > t, CD, R, N \\ \text{state}_S(\mathcal{M}, t', \text{output}(UA)) \not\models \text{announcement}(CD, R, N) \\ \& \text{state}_S(\mathcal{M}, t, \text{output}(CA)) \not\models \text{cutdown}(CD, N)$$

#### S3. Rationality of negotiation

The system  $S$  satisfies *rationality of negotiation* if the Utility Agent satisfies announcement rationality and each Customer Agent satisfies bid rationality. This is formally

defined as the conjunction of the Utility Agent rationality property U9 and for each Customer Agent the Customer Agent rationality property C4 defined below.

### S4. Required reward limitation

The system  $S$  satisfies *required reward limitation* if for each Customer Agent and each cut-down percentage, the required reward of the Customer Agent is at most the maximal reward that can be offered by the Utility Agent.

$$\forall CA \forall CD \quad rr_{CA}(CD) \leq mr_{UA}(CD)$$

The above property is an assumption for the whole system, used in the proofs. In addition to these properties a global *successfulness property* for the whole negotiation process could be defined. However, as successfulness depends on the perspective of a specific agent, the choice has been made to define successfulness as a property of an agent (cf. property U1 below). The successfulness of the whole negotiation process could be defined as the conjunction of the successfulness properties for all participating agents.

## 5.2 Properties of the Agents and the World

The properties of the Utility Agent, the Customer Agents, and the External World are defined in this section. Note that each of the properties is presented as a temporal statement either about all traces of the system  $S$  or about all traces of an agent. In the latter case the truth of the property does not depend on the environment of the agent. Section 5.3 discusses how the various properties are logically related.

### 5.2.1 Properties of the Utility Agent

#### U1. Successfulness of negotiation

The Utility Agent satisfies *successfulness of negotiation* if at some point in time  $t$  and for some negotiation round  $N$  the predicted overuse is less than or equal to the constant  $\text{max\_overuse}$ .

$$\forall \mathcal{M} \in \text{Traces}(S) \exists t, N \exists U \leq \text{max\_overuse} \\ \text{state}_S(\mathcal{M}, t, \text{output}(UA)) \models \text{predicted\_overuse}(U, N)$$

#### U2. Negotiation round generation effectiveness

The Utility Agent satisfies *negotiation round generation effectiveness* if the following holds: if and when predicted overuse is higher than the maximal overuse, a next negotiation round is initiated.

$$\forall \mathcal{M} \in \text{Traces}(UA) \forall t, N, U, CD, R \\ \left[ \begin{array}{l} \text{state}_{UA}(\mathcal{M}, t, \text{output}(UA)) \models \text{round}(N) \\ \& \text{state}_{UA}(\mathcal{M}, t, \text{output}(UA)) \models \text{predicted\_overuse}(U, N) \\ \& U > \text{max\_overuse} \\ \& \text{state}_{UA}(\mathcal{M}, t, \text{output}(UA)) \models \text{announcement}(CD, R, N) \\ \& R < mr_{UA}(CD) \end{array} \right] \\ \Rightarrow \exists t' > t \text{state}_{UA}(\mathcal{M}, t', \text{output}(UA)) \models \text{round}(N+1)$$

#### U3. Negotiation round generation groundedness

The Utility Agent satisfies *negotiation round generation groundedness* if the following holds: if the predicted overuse is at most the maximal overuse, then no new negotiation round is initiated.

$$\forall \mathcal{M} \in \text{Traces}(UA) \forall t, N, U \\ \text{state}_{UA}(\mathcal{M}, t, \text{output}(UA)) \models \text{predicted\_overuse}(U, N) \\ \& U \leq \text{max\_overuse} \\ \Rightarrow \forall t', N' > N \quad \text{state}_{UA}(\mathcal{M}, t', \text{output}(UA)) \not\models \text{round}(N')$$

#### U4. Announcement generation effectiveness

The Utility Agent satisfies *announcement generation effectiveness* if for each initiated negotiation round at least one announcement is generated.

$$\begin{aligned} & \forall \mathcal{M} \in \text{Traces(UA)} \forall t, N \\ & [ \text{state}_{\text{UA}}(\mathcal{M}, t, \text{output(UA)}) \models \text{round(N)} \\ & \Rightarrow \exists t' \geq t \forall \text{CD} \exists R \\ & \quad \text{state}_{\text{UA}}(\mathcal{M}, t', \text{output(UA)}) \models \text{announcement(CD, R, N)} ] \end{aligned}$$

#### U5. Announcement uniqueness

The Utility Agent satisfies *announcement uniqueness* if for each initiated negotiation round at most one announcement is generated.

$$\begin{aligned} & \forall \mathcal{M} \in \text{Traces(UA)} \forall t, t', N \forall \text{CD, R, R}' \\ & \text{state}_{\text{UA}}(\mathcal{M}, t, \text{output(UA)}) \models \text{announcement(CD, R, N)} \\ & \& \text{state}_{\text{UA}}(\mathcal{M}, t', \text{output(UA)}) \models \text{announcement(CD, R}', N) \\ & \Rightarrow R = R' \end{aligned}$$

#### U6. Announcement generation groundedness

The Utility Agent satisfies *announcement generation groundedness* if an announcement is only generated for initiated negotiation rounds.

$$\begin{aligned} & \forall \mathcal{M} \in \text{Traces(UA)} \forall t, N \forall \text{CD, R} \\ & \text{state}_{\text{UA}}(\mathcal{M}, t, \text{output(UA)}) \models \text{announcement(CD, R, N)} \\ & \Rightarrow \exists t' \leq t \text{state}_{\text{UA}}(\mathcal{M}, t', \text{output(UA)}) \models \text{round(N)} \end{aligned}$$

#### U7. Monotonicity of announcement

The Utility Agent satisfies *monotonicity of announcement* if for each announcement and each cut-down percentage the offered reward is at least the reward for the same cut-down percentage offered in the previous announcements.

$$\begin{aligned} & \forall \mathcal{M} \in \text{Traces(UA)} \forall t, t', N, N' \forall \text{CD, R, R}' \\ & \text{state}_{\text{UA}}(\mathcal{M}, t, \text{output(UA)}) \models \text{announcement(CD, R, N)} \\ & \& \text{state}_{\text{UA}}(\mathcal{M}, t', \text{output(UA)}) \models \text{announcement(CD, R}', N') \\ & \& N \leq N' \\ & \Rightarrow R \leq R' \end{aligned}$$

#### U8. Progress in announcement

The Utility Agent satisfies *progress in announcement* if for at least one cut-down percentage the difference between the currently announced reward and the previously announced reward is at least the positive constant  $m$  (announce margin)

$$\begin{aligned} & \forall \mathcal{M} \in \text{Traces(UA)} \forall t, t', N \exists \text{CD} \forall R, R' \\ & \text{state}_{\text{UA}}(\mathcal{M}, t, \text{output(UA)}) \models \text{announcement(CD, R, N)} \\ & \& \text{state}_{\text{UA}}(\mathcal{M}, t', \text{output(UA)}) \models \text{announcement(CD, R}', N+1) \\ & \Rightarrow R + m \leq R' \end{aligned}$$

#### U9. Announcement rationality

The Utility Agent satisfies *announcement rationality* if no announced reward is higher than the maximal reward plus the announce margin

$$\begin{aligned} & \forall \mathcal{M} \in \text{Traces(UA)} \forall t, N \forall \text{CD, R} \\ & \text{state}_{\text{UA}}(\mathcal{M}, t, \text{output(UA)}) \models \text{announcement(CD, R, N)} \\ & \Rightarrow R \leq \text{mr}_{\text{UA}}(\text{CD}) + \text{announce\_margin} \end{aligned}$$

#### U10. Finite termination of negotiation by UA

The Utility Agent satisfies *finite termination of negotiation* if a time point exists such that UA does not negotiate anymore after this time point.

$$\begin{aligned} & \forall \mathcal{M} \in \text{Traces(S)} \exists t \forall t' > t, \text{CD, R, N} \\ & \text{state}_{\text{S}}(\mathcal{M}, t', \text{output(UA)}) \not\models \text{announcement(CD, R, N)} \end{aligned}$$

## 5.2.2 Properties of each Customer Agent

### C1. Bid generation effectiveness

A Customer Agent CA satisfies *bid generation effectiveness* if for each announced negotiation round at least one bid is generated (possibly a bid for reduction zero).

$$\begin{aligned} & \forall \mathcal{M} \in \text{Traces(CA)} \forall t, N \\ & \text{state}_{\text{CA}}(\mathcal{M}, t, \text{input(CA)}) \models \text{round(N)} \\ & \Rightarrow \exists \text{CD, } t' \geq t \text{state}_{\text{CA}}(\mathcal{M}, t', \text{output(CA)}) \models \text{cutoff(CD, N)} \end{aligned}$$

### C2. Bid uniqueness

A Customer Agent CA satisfies *bid uniqueness* if for each negotiation round at most one bid is generated.

$$\begin{aligned} & \forall \mathcal{M} \in \text{Traces(CA)} \forall t, t', N, \text{CD, CD}' \\ & \text{state}_{\text{CA}}(\mathcal{M}, t, \text{output(CA)}) \models \text{cutoff(CD, N)} \\ & \& \text{state}_{\text{CA}}(\mathcal{M}, t', \text{output(CA)}) \models \text{cutoff(CD}', N) \\ & \Rightarrow \text{CD} = \text{CD}' \end{aligned}$$

### C3. Bid generation groundedness

A Customer Agent CA satisfies *bid generation groundedness* if a bid is only generated once a negotiation round is announced.

$$\begin{aligned} & \forall \mathcal{M} \in \text{Traces(CA)} \forall t, N, \text{CD} \\ & \text{state}_{\text{CA}}(\mathcal{M}, t, \text{output(CA)}) \models \text{cutoff(CD, N)} \\ & \Rightarrow \exists t' \leq t \text{state}_{\text{CA}}(\mathcal{M}, t', \text{input(CA)}) \models \text{round(N)} \end{aligned}$$

### C4. Bid rationality

A Customer Agent CA satisfies *bid rationality* if for each bid the required reward for the offered cut-down is at most the reward announced in the same round, and the offered cut-down is the highest with this property.

$$\begin{aligned} & \forall \mathcal{M} \in \text{Traces(CA)} \forall t, t', N, \text{CD} \\ & [ \text{state}_{\text{CA}}(\mathcal{M}, t, \text{output(CA)}) \models \text{cutoff(CD, N)} \\ & \& \text{state}_{\text{CA}}(\mathcal{M}, t', \text{input(CA)}) \models \text{announcement(CD, R, N)} \\ & \Rightarrow \text{rr}_{\text{CA}}(\text{CD}) \leq R ] \\ & \& \\ & [ \text{state}_{\text{CA}}(\mathcal{M}, t, \text{output(CA)}) \models \text{cutoff(CD, N)} \\ & \& \text{state}_{\text{CA}}(\mathcal{M}, t, \text{input(CA)}) \models \text{announcement(CD, R, N)} \\ & \& \text{state}_{\text{CA}}(\mathcal{M}, t', \text{input(CA)}) \models \text{announcement(CD}', R', N) \\ & \& \text{rr}_{\text{CA}}(\text{CD}') \leq R' ] \\ & \Rightarrow \text{CD} \geq \text{CD}' \end{aligned}$$

### C5. Monotonicity of bids

A Customer Agent CA satisfies *monotonicity of bids* if each bid is at least as high (a cut-down percentage) as the bids for the previous rounds.

$$\begin{aligned} & \forall \mathcal{M} \in \text{Traces(S)} \forall t, t', N, N' \forall \text{CD, CD}' \\ & \text{state}_{\text{S}}(\mathcal{M}, t, \text{output(CA)}) \models \text{cutoff(CD, N)} \\ & \& \text{state}_{\text{S}}(\mathcal{M}, t', \text{output(CA)}) \models \text{cutoff(CD}', N') \\ & \& N \leq N' \\ & \Rightarrow \text{CD} \leq \text{CD}' \end{aligned}$$

### C6. Finite termination of negotiation by CA

A Customer Agent CA satisfies *finite termination of negotiation by CA* if a time point exists such that CA does not negotiate anymore after this time point.

$$\begin{aligned} & \forall \mathcal{M} \in \text{Traces(S)} \exists t \forall t' > t, \text{CD, N} \\ & \text{state}_{\text{S}}(\mathcal{M}, t', \text{output(CA)}) \not\models \text{cutoff(CD, N)} \end{aligned}$$

A successfulness property of a Customer Agent could be defined on the basis of some balance between discomfort and financial gains.

### 5.2.3 Properties of the External World

The External World satisfies *information provision effectiveness* if it provides information about the predicted use of energy, the maximum energy level allocated to each Customer Agent, and the maximal overuse of the Utility Agent. The External World satisfies *static world* if the information provided by the external world does not change during a negotiation process.

### 5.3 Proving Properties

To structure proofs of properties, the compositional structure of the system is followed. For the level of the whole system, system properties are proved from agent properties, which are defined at one process abstraction level lower.

#### 5.3.1 Proofs of the System Properties

Property S4 is an assumption on the system, which is used in the proofs of other properties. The other top level properties can be proven from the agent properties in a relatively simple manner. For example, by definition monotonicity of negotiation (S1) can be proven from the properties monotonicity of announcement (U7) and monotonicity of bids (C5) for all Customer Agents. Also S2 (termination) can be proven directly from U10 and C6, and S3 (rationality) immediately follows from U9 and C4.

#### 5.3.2 Proofs of Agent Properties

Less trivial relationships can be found between agent properties. As an example, the termination property for the Utility Agent (U10) can be proven from the properties U1, U3, and U6. The termination property of a Customer Agent depends on the Utility Agent, since the Customer Agents are reactive: the proof of C6 makes use of C3, and the Utility Agent properties U1 and U3, and the assumption that the communication between UA and CA functions properly (CA should not receive round information that was not generated by UA). In the proofs of an agent property, also properties of sub-components of the agent can be used: the proof can be made at one process abstraction level lower. This will be discussed for the Utility Agent in Section 6.

## 6. Verification within the Utility Agent

To illustrate the next level in the compositional verification process, in this section it is discussed how properties of the Utility Agent can be related to properties of components within the Utility Agent. First some of the properties of the components Agent Interaction Management and Determine Balance are defined.

### 6.1 Properties of Components within UA

Properties are defined for the components Agent Interaction Management (AIM), Determine Balance (DB), Cooperation Management (CM), and Own Process Control (OPC) of the Utility Agent (see Figure 1).

#### 6.1.1 Properties of AIM

The following two properties express that the component Agent Interaction Management (1) distributes the relevant

information from incoming communication, and (2) generates outgoing communication if required.

#### AIM1. Cut-down provision effectiveness

The component Agent Interaction Management satisfies *cut-down provision effectiveness* if AIM is effective in the analysis of incoming communication: the cut-down information received by AIM of the form  $\text{received}(\text{cutdown\_from}(\text{CD}, \text{CA}, \text{N}))$  is interpreted and translated into cut-down information required by other components of the form  $\text{offered\_bid}(\text{cutdown}(\text{CD}, \text{CA}, \text{N}))$  and made available in AIM's output interface.

$$\begin{aligned} & \forall \mathcal{M} \in \text{Traces}(\text{AIM}) \forall t, N, \text{CD}, \text{CA} \\ & \text{state}_{\mathcal{M}}(\mathcal{M}, t, \text{input}(\text{AIM})) \models \text{received}(\text{cutdown\_from}(\text{CD}, \text{CA}, \text{N})) \\ & \Rightarrow \exists t' > t \text{state}_{\mathcal{M}}(\mathcal{M}, t', \text{output}(\text{AIM})) \models \text{offered\_bid}(\text{cutdown}(\text{CD}, \text{CA}, \text{N})) \end{aligned}$$

#### AIM2. Communication generation effectiveness

The component Agent Interaction Management satisfies *communication generation effectiveness* if AIM is effective in generation of outgoing communication on the basis of the analysis of input information received from other components of the form  $\text{next\_communication}(\text{round}(\text{N}))$ ,  $\text{next\_communication}(\text{announcement}(\text{CD}, \text{R}, \text{N}))$  which is made available in statements  $\text{own\_communication}(\text{round}(\text{N}))$ , and  $\text{own\_communication}(\text{announcement}(\text{CD}, \text{R}, \text{N}))$ .

$$\begin{aligned} & \forall \mathcal{M} \in \text{Traces}(\text{AIM}) \forall t, N, \text{CD} \\ & \text{state}_{\text{AIM}}(\mathcal{M}, t, \text{input}(\text{AIM})) \models \text{next\_communication}(X) \\ & \Rightarrow \exists t' > t \text{state}_{\text{AIM}}(\mathcal{M}, t', \text{output}(\text{AIM})) \models \text{own\_communication}(X) \end{aligned}$$

### 6.1.2 Properties of Determine Balance

The following two properties express that the component Determine Balance calculates predictions in a reasonable manner.

#### DB1. Overuse prediction generation effectiveness

The component Determine Balance satisfies *overuse prediction generation effectiveness* if the predicted overuse is determined if and when normal capacity, predicted use and cut-downs are known.

$$\begin{aligned} & \forall \mathcal{M} \in \text{Traces}(\text{DB}) \forall t, N, C \\ & \text{state}_{\text{DB}}(\mathcal{M}, t, \text{input}(\text{DB})) \models \text{predicted\_use}(U) \\ & \& \text{state}_{\text{DB}}(\mathcal{M}, t, \text{input}(\text{DB})) \models \text{normal\_capacity}(C) \\ & \& \forall \text{CA} \exists \text{CD} \text{state}_{\text{DB}}(\mathcal{M}, t, \text{input}(\text{DB})) \models \text{cutdown\_from}(\text{CD}, \text{CA}, \text{N}) \\ & \& \text{state}_{\text{DB}}(\mathcal{M}, t, \text{output}(\text{DB})) \models \text{round}(\text{N}) \\ & \Rightarrow \exists U', t' > t \text{state}_{\text{DB}}(\mathcal{M}, t', \text{output}(\text{DB})) \models \text{predicted\_overuse}(U', \text{N}) \end{aligned}$$

#### DB2. Overuse prediction monotonicity

The component Determine Balance satisfies *overuse prediction monotonicity* if the following holds: if based on received cut-downs  $\text{CD}_{\text{CA}}$  for each Customer Agent CA, a predicted overuse  $U$  is generated by DB, and based on received cut-downs  $\text{CD}'_{\text{CA}}$  for each Customer Agent CA, a predicted overuse  $U'$  is generated by DB, then  $\text{CD}_{\text{CA}} \leq \text{CD}'_{\text{CA}}$  for all CA implies  $U' \leq U$ .

$$\begin{aligned} & \forall \mathcal{M} \in \text{Traces}(\text{DB}) \forall t, t', N, N', C, U0, U, U' \\ & \text{state}_{\text{DB}}(\mathcal{M}, t, \text{input}(\text{DB})) \models \text{predicted\_use}(U0) \\ & \& \forall \text{CA} [ \text{state}_{\text{DB}}(\mathcal{M}, t, \text{input}(\text{DB})) \models \text{cutdown\_from}(\text{CD}_{\text{CA}}, \text{CA}, \text{N}) \\ & \& \text{state}_{\text{DB}}(\mathcal{M}, t', \text{input}(\text{DB})) \models \text{cutdown\_from}(\text{CD}'_{\text{CA}}, \text{CA}, \text{N}') \\ & \& \text{CD}_{\text{CA}} \leq \text{CD}'_{\text{CA}} ] \\ & \& \text{state}_{\text{DB}}(\mathcal{M}, t, \text{output}(\text{DB})) \models \text{predicted\_overuse}(U, \text{N}) \\ & \& \text{state}_{\text{DB}}(\mathcal{M}, t', \text{output}(\text{DB})) \models \text{predicted\_overuse}(U', \text{N}') \\ & \Rightarrow U' \leq U \end{aligned}$$

Note that in this property the monotonicity is not meant over time, but for the functional relation between input and output of DB.

### DB3. Overuse prediction decrease effectiveness

The component Determine Balance satisfies *overuse prediction decrease effectiveness* if the following holds: cut-down values exist such that, if the Utility Agent receives them, the predicted overuse will be at most the maximal overuse. Formally, a collection of numbers  $CD_{CA}$  for each Customer Agent CA exists such that:

$$\begin{aligned} & \forall \mathcal{M} \in \text{Traces}(\text{DB}) \quad \forall t, N \\ & \quad \forall CA \text{ state}_{\text{DB}}(\mathcal{M}, t, \text{input}(\text{DB})) \models \text{cutdown\_from}(CD_{CA}, CA, N) \\ & \Rightarrow \exists t' > t, U \leq \text{max\_overuse} \\ & \quad \text{state}_{\text{DB}}(\mathcal{M}, t', \text{output}(\text{DB})) \models \text{predicted\_overuse}(U, N) \end{aligned}$$

#### 6.1.3 Properties of Cooperation Management

Cooperation Management fulfills a number of properties, for example on properly generation announcements: announcement generation effectiveness, announcement uniqueness, and announcement generation groundedness. These are defined similarly to the corresponding properties of the Utility Agent. In this paper only the property that guarantees that new rounds are initiated is explicitly stated.

### CM1. Round generation effectiveness

The component Determine Balance satisfies *round generation effectiveness* if CM determines the value of the next round and makes this information available to other components in its output interface.

$$\begin{aligned} & \forall \mathcal{M} \in \text{Traces}(\text{CM}) \quad \forall t, N \\ & \quad \text{state}_{\text{CM}}(\mathcal{M}, t, \text{input}(\text{CM})) \models \text{round}(N) \\ & \Rightarrow \exists t' > t \text{ state}_{\text{CM}}(\mathcal{M}, t', \text{output}(\text{DB})) \models \text{round}(N+1) \end{aligned}$$

#### 6.1.4 Properties of Own Process Control

One of the properties of the component Own Process Control guarantees that decisions about continuation of a negotiation process are made:

### OPC1. New announce decision effectiveness

If the predicted overuse is still more than the maximum overuse, then a new announcement is warranted.

$$\begin{aligned} & \forall \mathcal{M} \in \text{Traces}(\text{OPC}) \quad \forall t, N, U \\ & \quad \text{state}_{\text{OPC}}(\mathcal{M}, t, \text{input}(\text{OPC})) \models \text{current\_negotiation\_state} \\ & \quad \quad \quad \text{predicted\_overuse}(U, N) \\ & \quad \& \text{state}_{\text{OPC}}(\mathcal{M}, t, \text{input}(\text{OPC})) \models \text{current\_negotiation\_state}(\text{round}(N)) \\ & \quad \& U > \text{max\_overuse} \\ & \Rightarrow \exists t' > t, \text{state}_{\text{OPC}}(\mathcal{M}, t', \text{output}(\text{OPC})) \models \text{new\_announce} \end{aligned}$$

## 6.2 Proofs within the Utility Agent

To verify the UA property U2 (*negotiation round generation effectiveness*), a number of properties of sub-components, are of importance, and also the interaction between the components through the information links (the arrows in Figure 1) should function properly. The following gives a brief sketch of the proof of the UA property negotiation round generation effectiveness.

The round number itself is determined by CM; to guarantee this, CM needs to satisfy the property of *round generation effectiveness* (CM1). This round value is transferred to the component AIM. The component AIM must fulfil the property of *communication generation effectiveness* (AIM2) to enable this value to be placed in the Utility Agent's output interface, once the relevant link has been activated. Activation of the link to the Utility Agent's output interface depends (via task control) on whether the component OPC derives the need for a new

announcement. To guarantee this, the property *new announce decision effectiveness* (OPC1), is needed.

Based on the properties mentioned, the proof runs as follows. Whenever the component AIM has received all the cut-downs for the current round, the link bids from AIM to DB is activated (via task control). Because of the property BD1 (*overuse prediction generation effectiveness*), this component then derives the current predicted overuse (assuming predicted use, normal capacity and round are known). It can be assumed that the overuse for this round is above  $\text{max\_overuse}$  (otherwise the conditions for U2 are not satisfied). The component OPC is then activated (by task control) and, given property OPC1 (*new announce decision effectiveness*) this component will derive the atom  $\text{new\_announce}$ . Then Cooperation Management is activated and given property CM1, this component will derive a new round. Given property AIM2, this new round information will be available on the output interface of AIM; the link outgoing communications transfers the desired result:  $\text{round}(N+1)$  at the output of UA. This proves Utility Agent property U2.

## 7. Discussion

To come to clearer understanding of strengths and weaknesses of a compositional approach to verification it is important to address real world problems where size and/or complexity are characteristic. The load balancing problem of electricity use, as addressed in this paper, belongs to the class of real world problems. This paper focuses on one-to-many negotiation between a Utility Agent and its Customer Agents, using a (monotonic) negotiation strategy based on announcing reward tables.

The compositional verification method used in this paper is part of the compositional development method for multi-agent systems DÉSIRE, based on compositionality of processes and knowledge at different levels of abstraction, but can also be useful to other compositional approaches. Two main advantages of a compositional approach to modelling are the transparent structure of the design and support for reuse of components and generic models. The compositional verification method extends these main advantages to (1) the complexity of the verification process is managed by compositionality, and (2) the proofs of properties of components that are reused can be reused.

The first advantage entails that both conceptually and computationally the complexity of the verification process can be handled by compositionality at different levels of abstraction. The second advantage entails: if a modified component satisfies the same properties as the one it replaces, the proof of the properties at the higher levels of abstraction can be reused to show that the new system has the same properties as the original system. This increases the value for a documented library of reusable generic and instantiated components.

Also due to the compositional nature of the verification method, a distributed approach to verification is facilitated: several persons can work on the verification of the same system at the same time. It is only necessary to know or to agree on the properties of these sub-components with interfaces in common.

A main difference in comparison to [9] is that our approach exploits compositionality. An advantage of their



approach is that it uses a temporal belief logic. A first step to extend our approach a compositional variant of temporal logic can be found in [7]. A main difference to the work described in [3] and [8] is that in our approach compositionality of the verification is addressed; in the work as referred only domain assumptions are taken into account, and no hierarchical relations between properties are defined.

A future continuation of this work will address both the embedding of verification proofs in a suitable proof system for temporal logic (for some first results, see [7]), and the development of tools for verification. At the moment only tools exist for the verification of primitive components; no tools for the verification of composed components exist yet. To support the handwork of verification it would be useful to have tools to assist in the creation of the proof. This could be done by formalising the proofs of a verification process in a suitable proof system.

## References

- [1] Abadi, M. and Lamport, L., Composing Specifications, *ACM Transactions on Programming Languages and Systems*, Vol. 15, No. 1, 1993, p. 73-132.
- [2] Akkermans, H., Ygge, F., and Gustavsson, R., HOMEBOOTS: Intelligent Decentralized Services for Energy Management. In: *Proceedings of the Fourth International Symposium on the Management of Industrial and Corporate Knowledge, ISMICK'96*, 1996.
- [3] Benjamins, R., Fensel, D., and Straatman, R., Assumptions of problem-solving methods and their role in knowledge engineering. In: W. Wahlster (ed.), *Proceedings of the 12th European Conference on AI, ECAI'96*, John Wiley and Sons, 1996, pp. 408-412.
- [4] Brazier, F.M.T., Cornelissen, F., Gustavsson, R., Jonker, C.M., Lindeberg, O., Polak, B., and Treur, J., Agents Negotiating for Load Balancing of Electricity Use. In: M.P. Papazoglou (ed.), *Proc. of the 18th International Conference on Distributed Computing Systems, ICDCS'98*. IEEE Computer Society Press, 1998. In press.
- [5] Brazier, F.M.T., Dunin-Keplicz, B., Jennings, N.R., and Treur, J., Formal specification of Multi-Agent Systems: a real-world case. In: V. Lesser (ed.), *Proc tasks*. In: B.R. Gaines, M.A. Musen (eds.), *Proceedings of the First International Conference on Multi-Agent Systems, ICMAS'95*, MIT Press, Cambridge, MA, 1995, pp. 25-32. Extended version in: *International Journal of Cooperative Information Systems*, M. Huhns, M. Singh, (eds.), special issue on Formal Methods in Cooperative Information Systems: Multi-Agent Systems, vol. 6, 1997, pp. 67-94.
- [6] Brazier, F.M.T., Treur, J., Wijngaards, N.J.E., and Willems, M., Temporal semantics of complex reasoning tasks. In: B.R. Gaines, M.A. Musen (eds.), *Proceedings of the 10th Banff Knowledge Acquisition for Knowledge-based Systems workshop, KAW'96*, Calgary: SRDG Publications, Department of Computer Science, University of Calgary, 1996, pp. 15/1-15/17. Extended version to appear in *Data and Knowledge Engineering*, 1998.
- [7] Engelfriet, J., Jonker, C.M., and Treur, J., Compositional Verification of Multi-Agent Systems in Temporal Multi-Epistemic Logic. In: J.P. Müller, A.S. Rao, M.P. Singh (eds.), *Proceedings of the Fifth International Workshop on Agent Theories, Architectures and Languages, ATAL'98*, 1998. To be published by Springer Verlag.
- [8] Fensel, D., Schonegge, A., Groenboom, R., and Wielinga, B., Specification and verification of knowledge-based systems. In: B.R. Gaines, M.A. Musen (eds.), *Proceedings of the 10th Banff Knowledge Acquisition for Knowledge-based Systems workshop, KAW'96*, Calgary: SRDG Publications, Department of Computer Science, University of Calgary, 1996, pp. 4/1-4/20.
- [9] Fisher, M., and Wooldridge, M., On the Formal Specification and Verification of Multi-Agent Systems. In: *International Journal of Cooperative Information Systems*, M. Huhns, M. Singh, (eds.), special issue on Formal Methods in Cooperative Information Systems: Multi-Agent Systems, vol. 6, 1997, pp. 67-94.
- [10] Gustavsson, R., Requirements on Information Systems as Business Enablers. Invited paper. In *Proceedings of DA/DSM Europe DistribuTECH'97*, PennWell, 1997.
- [11] Hooman, J., Compositional Verification of a Distributed Real-Time Arbitration Protocol. In: *Real-Time Systems*, vol. 6, 1997, pp. 173-206.
- [12] Jonker, C.M., and Treur, J., Compositional verification of multi-agent systems: a formal analysis of pro-activeness and reactiveness. In: W.P. de Roever, H. Langmaack, A. Pnueli (eds.), *Proceedings of the International Workshop on Compositionality, COMPOS'97*, Springer Verlag, 1998. In press.
- [13] Kinny, D., Georgeff, M.P., and Rao, A.S., A Methodology and Technique for Systems of BDI Agents. In: W. van der Velde, J.W. Perram (eds.), *Agents Breaking Away, Proceedings of the 7th European Workshop on Modelling Autonomous Agents in a Multi-Agent World, MAAMAW'96*, Lecture Notes in AI, vol. 1038, Springer Verlag, 1996, pp. 56-71.
- [14] Rosenschein, J.S., and Zlotkin, G., *Rules of Encounter: Designing Conventions for Automated Negotiation among Computers*, MIT Press, 1994.
- [15] Rosenschein, J.S., and Zlotkin, G., Designing Conventions for Automated Negotiation, In: *AI Magazine*, Vol. 15-3, Fall 1994, pp. 29-46.